



WILLOW

A MAJOR FOOD GROUP RESIDENTIAL EXPERIENCE

BAYFRONT RESIDENCES • EDGEWATER MIAMI

MIAMI











**“A PLACE ANSWERING
THE CRAVING FOR
OLD-WORLD ELEGANCE
WITH A KEEN
SENSE OF THE WAY
LIFE IS BEST LIVED”**

MARIO CARBONE

CONTENTS

01	A GRAND VISION	16
02	EDGEWATER: COASTAL GEM	66
03	AMENITY DESIGN	90
04	RESIDENCE DESIGN	152
05	TOWER & GROUNDS	200
06	A LIFE CURATED	236



01

A GRAND VISION

**A NEW ERA OF WATERFRONT LIVING DAWNS IN THIS
COSMOPOLITAN OASIS, A CITY UNLIKE ANY OTHER**

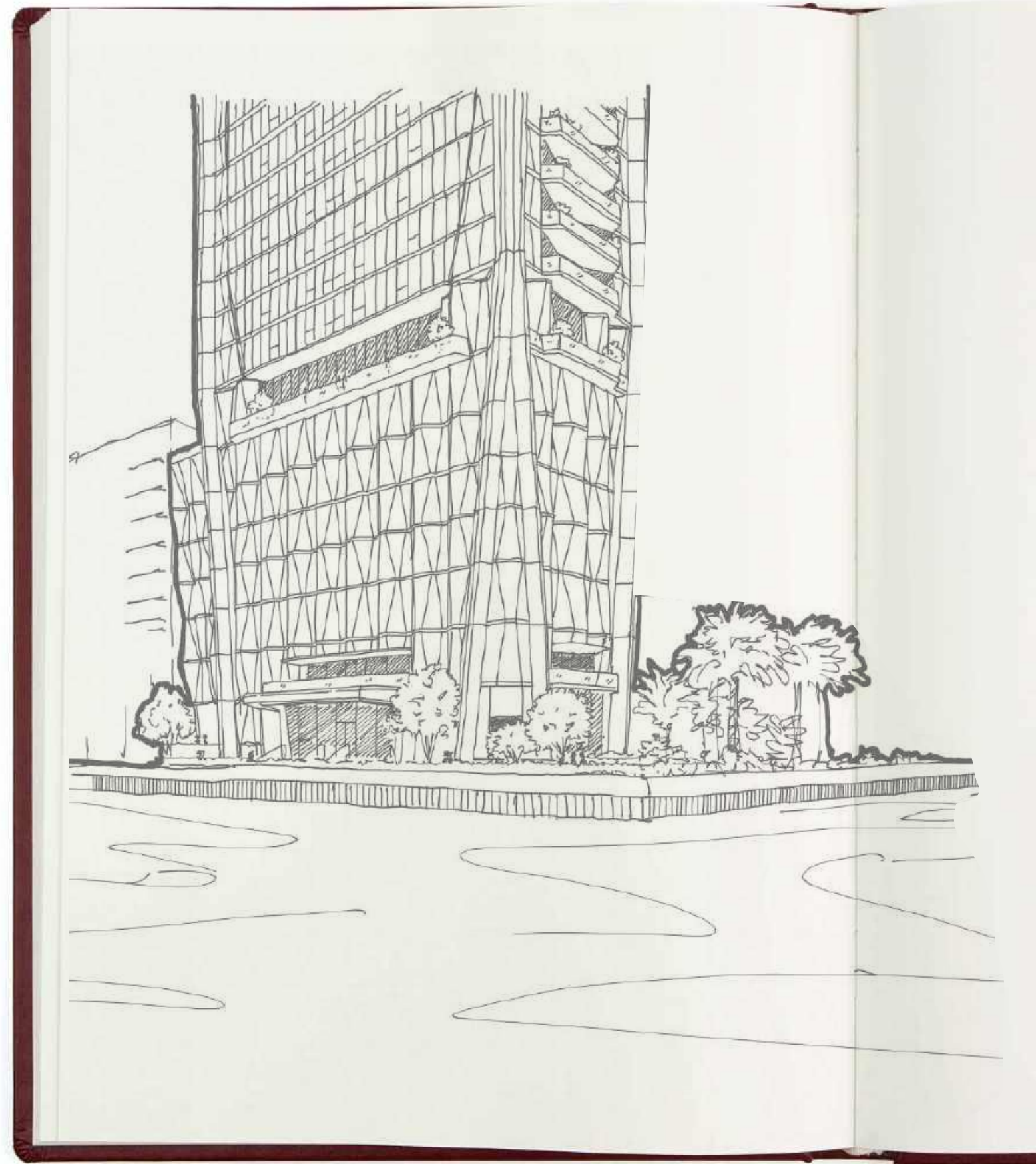

Villa Miami's architecture highlights its unique location, perched on the edge of Biscayne Bay and surrounded by unrivaled views of the water.

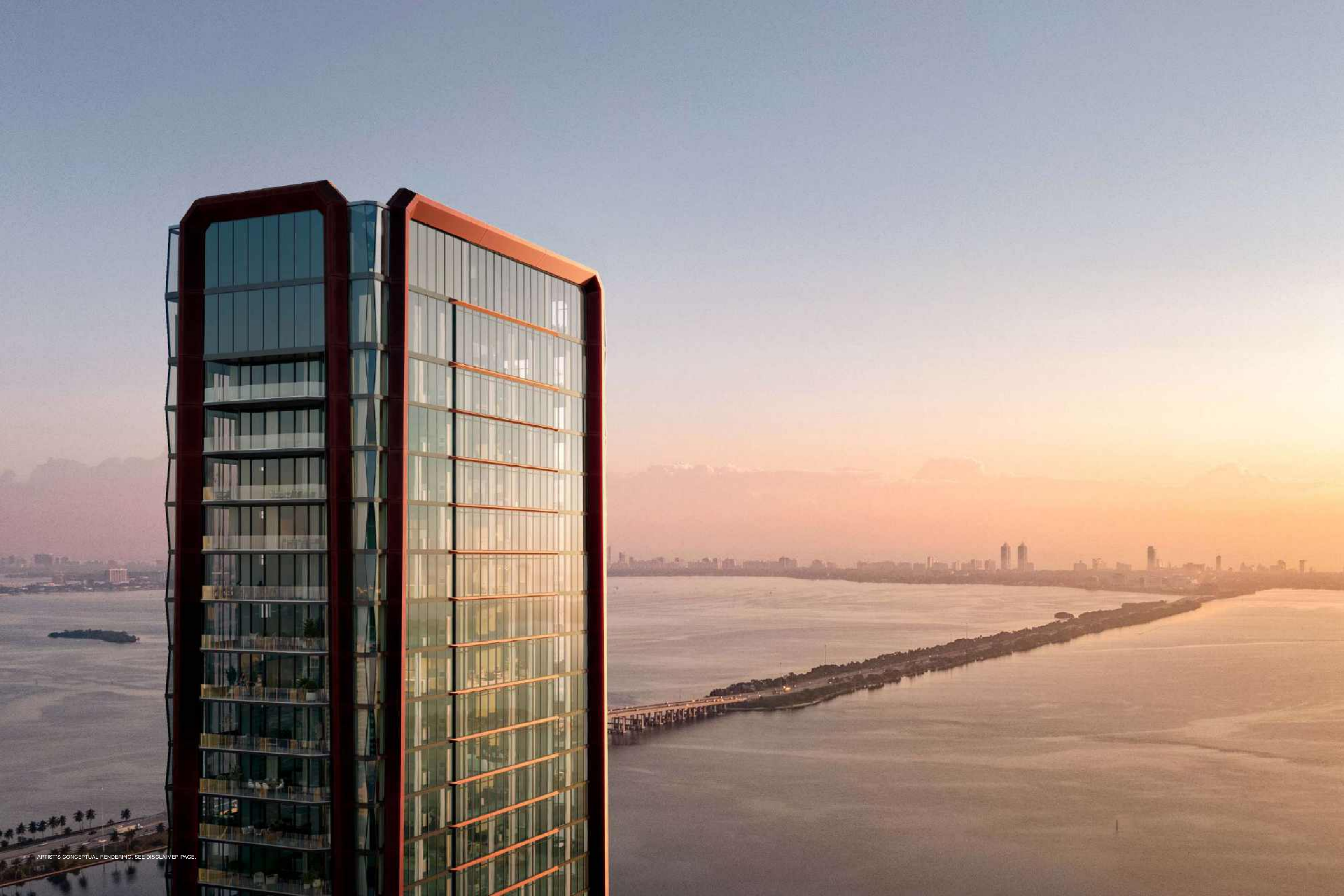

ARTIST'S CONCEPTUAL RENDERING. SEE DISCLAIMER PAGE.

HEAD IN THE SKY WITH A HAND IN THE WATER

Chart a course through the miles of Miami's sunny waterways and bustling boulevards and you'll feel it. This city is buzzing. A diverse community, saturated in culture, is being reinvented for a new era. One more sophisticated, ambitious and globally influential than ever before, propelled by a new generation of dreamers who see the city of the future forming before their eyes.

Emerging from the center of this is Villa Miami, a towering jewel of a home where a new vision of waterfront living thrives, inspired by the romance and sophistication of European coastal towns. A life lived here is imbued with a rich warmth and languid glamour amidst the vibrant energy of a whole new Miami.



| Sprawling, full-floor residences offer estate-style living with miles of horizon views.



| The water beckons just outside Villa Miami's doors, steps from our private boat slip.

Villa Miami is the fruit of a collaboration between a dream team of creatives and builders, including Major Food Group (MFG), the masterminds behind Carbone, Contessa, ZZ's Club and Sadelle's. For the first time, MFG has extended its robust, maximalist approach to unforgettable evenings to an entire lifestyle, developing everything from a new restaurant concept to chef-worthy home kitchens. They've hand-selected a globally recognized team to bring this vision of new waterfront living to life. From ODP Architects who designed the building's crystalline exterior to reflect the sparkling bayfront, to interior designer Vicky Charles, who infuses all her work with a sense of warm materiality and romance, each element of this endeavor is impeccably and thoughtfully approached.

At Villa Miami every day is charmed, full of sophistication, and ease. Wake up to panoramic views of the Venetian Islands and beaches beyond. A breeze coming off the bay drifts inside. Spend the morning unwinding in the Mediterranean spa, skimming across town by boat and heading out by helicopter. As the day wanes, stop by a wine tasting in the members' lounge, or revel late into the night at the city's best new restaurant — a new MFG concept — which just happens to be downstairs. Your table is waiting for you. Dinner on the veranda is paired with a sunset refracted in the water beyond. It's all possible,

carefully orchestrated by our in-house curators and Major Domo. Here, the sun meets the sea, vacation never ends, and the dock is always waiting. Every bite is planned to perfection.



The arrival of Villa Miami cements Edgewater as the center of the new Miami. Known for its bayfront parks and unbeatable proximity to the best culture and dining the city has to offer, Edgewater is a hub of new and established restaurants located minutes from the Design District to the north, Wynwood to the west, and Brickell to the south.

The new Miami is much more than its beaches. It's a global destination for contemporary art, fine dining, shopping and commerce — all happening minutes from Edgewater, where the entire city is visible from Villa Miami's sprawling windows.

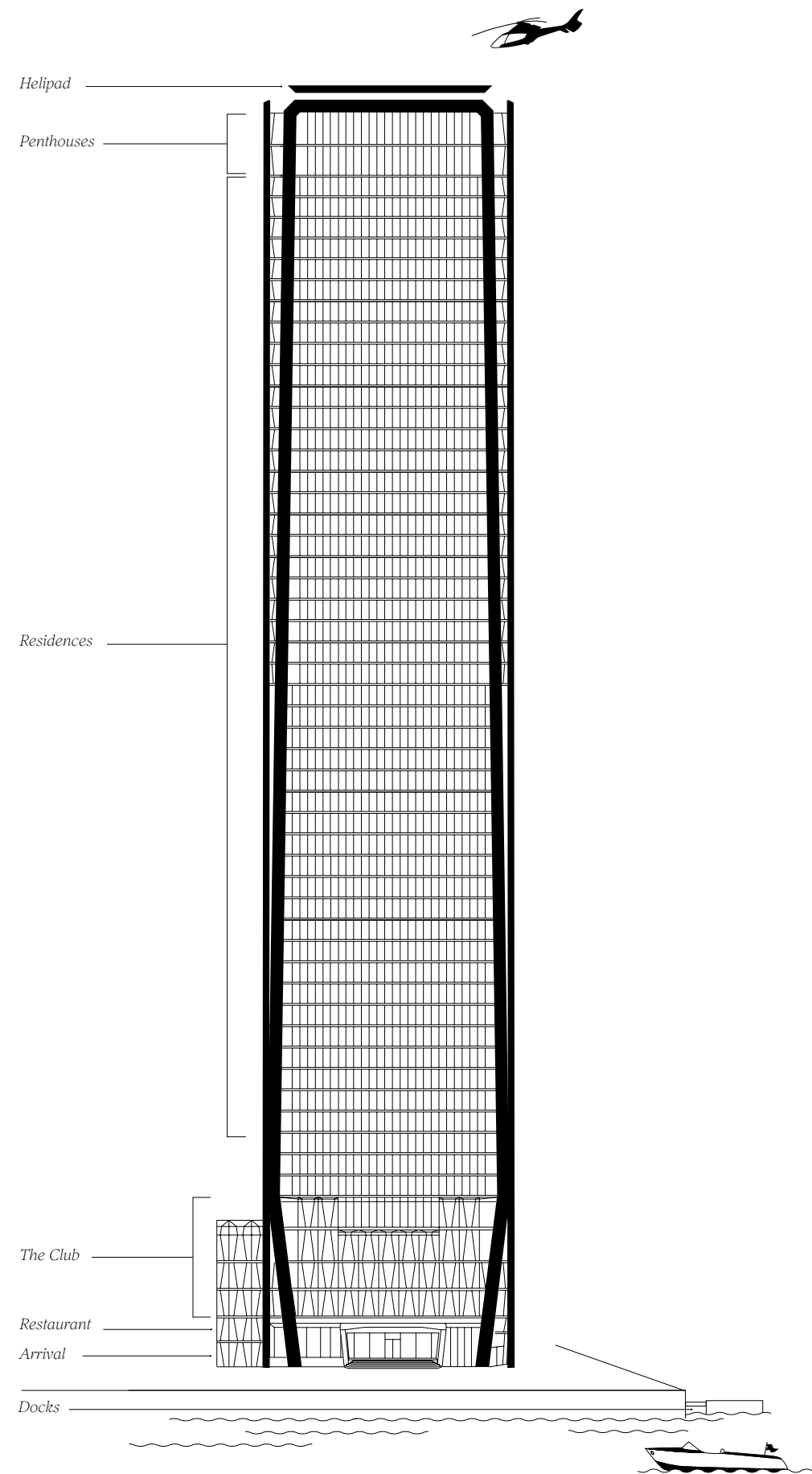

ROOFTOP

HELIPAD

- Rooftop helipad for Seamless Arrivals and Departures

LEVELS 53 - 55

PENTHOUSES

- Penthouse Residences

LEVELS 6 - 52

RESIDENCES

- Full-Floor Villa Piano Residences
- Half-Floor Villa Mezzo Residences

LEVELS 3 - 5

THE CLUB

- Spa, Salon, Sauna, Herbal Steam Room, Hot and Cold Plunge Pools, & Men's and Women's Locker Rooms
- Relaxation Lounge
- Fitness Center & Fitness Training Rooms
- Outdoor Pool
- Game Room, Screening Room, Family Lounge
- Major Domo & In-House Curator
- Private Residential Dining
- Great Room Bar & Lounge
- Conference Rooms

LEVEL 2

RESTAURANT

- MFG Restaurant Second Level

LEVEL 1

ARRIVAL

- Lobby
- MFG Restaurant & Bar with Outdoor Terrace
- Baywalk
- Docks
- Covered Drop Off



THE ART OF REINVENTING CLASSICS

It sounds deceptively simple. Take delicious, exceptionally well-prepared food and present it somewhere comfortable but elegant, unpretentious but unquestionably curated. And yet, a night out with Major Food Group is a night unlike any other. Menus are classic yet rarified, the ambiance glows and crackles, and the staff always seems to know what you want next.

Getting a table is the hard part. But what if wasn't?



From Greenwich Village to South Beach, Carbone has seduced audiences with its decadent dishes and impeccable service since it first opened in Manhattan in 2013. Today, Major Food Group, whose three founding partners are all born-and-bred New Yorkers, considers Miami a second home. The city is now the site of some of MFG's most innovative ventures, including Villa Miami, where the daily lifestyle will reflect the Old World glamour that defines its famous restaurants.

A PHILOSOPHY OF BOUNDLESS OPULENCE TRAVELS WORLDWIDE



Fine dining in New York City had become staid. That was one of the provocative ideas that first bonded the chefs Rich Torrisi and Mario Carbone. Friends from culinary school, they reconnected while working for some of the city's most respected restaurants in the first decade of 2000s. Undaunted and eager to make their own mark on the city, they decided to go into business together. Their first restaurant opened in 2009 — a sandwich deli downtown with an ambitious dinner menu named Torrisi Italian Specialties. Word quickly spread about a dining experience unlike any in the city, hailed by critics as a revolution in red-sauce dining. The duo recast classic Italian American dishes, using them as canvases for refined and inventive explorations of flavor. Entrepreneur Jeff Zalaznick took notice and bonded with the chefs over the joy of classic dishes, New York history and their shared ambition to become bombastic restaurateurs. With no shortage of verve and imagination, the trio formed Major Food Group and got to work living

up to their name. No restaurant more than Carbone, which first opened on Thompson Street in 2013, has better exemplified their approach. Stepping inside the darkly lit dining room feels like stepping back in time — to an era when grey-haired waiters wore velvet tuxedos, Frank Sinatra was on the soundtrack, and dinner was the show. Today, the restaurant has become a destination for its impeccably updated classic dishes as much as for the ambiance, brimming over with unabashed nostalgia, vibrant style and extravagance.

Since Carbone cemented its reputation for maximalist excellence, Major Food Group has kept expanding, opening new restaurant concepts, private clubs and hotels that carry the founders' ever-present commitment to old-world hospitality and exceptional food. Today, the group operates two dozen properties in six countries and has embraced Miami as another home, opening locations of their most beloved restaurants in South Beach, the Design District, Coconut Grove and Brickell. Their latest restaurant — a completely new concept with an Italian focus — will serve as the heart and soul of Villa Miami, where residents will be welcomed like regulars.



Major Food Group's influence at Villa Miami extends beyond the food and beverage experiences. Its philosophy of boundless opulence will be felt from the waterfront access to the vast, airy residences equipped with chef-worthy kitchens. And MFG's appreciation for traditional, Italian glamour is reflected in the warm, lush interior design, as well as in Villa Miami's on-staff curator and discerning support staff. The result is waterfront living reimagined for a new Miami — elegant, indulgent and refreshingly familiar.



CONCEPTS

**CARBONE
CARBONE VINO
CHATEAU ZZ'S
CONTESSA**

**CROWN CLUB
DIRTY FRENCH
DIRTY FRENCH STEAKHOUSE
HASALON**

**JAPANESE BOCCE CLUB
L'AMI DAVE
PARM
PRINCIPESSA**

**SADALLE'S
STREET BAR
THE BOCA RATON
THE FLAMINGO GRILL**

**THE GRILL
THE LOBSTER CLUB
THE LUDLOW HOTEL
THE NEWBURY BOSTON**

**THE POOL
TORRISI
ZZ'S CLAM BAR
ZZ'S CLUB**



Sadelle's – Miami, FL



Carbone – Miami, FL



Dirty French – Miami, FL



Carbone – Las Vegas, NV



ZZ's Club – Miami, FL



Torrissi – New York, NY



ZZ's Club – New York, NY



HaSalon – Miami, FL



Carbone – New York, NY



Contessa – Miami, FL



The Grill – New York, NY



The Pool Lounge – New York, NY



Flamingo Grill – Boca Raton, FL



The Lobster Club – New York, NY



Contessa – Boston, MA



Chateau ZZ's – Miami, FL

A TASTE OF THE MFG WORLD

From Saddle's to Dirty French and Contessa, every MFG property is designed with an eye for tradition, style and a nostalgic glamour evident everywhere from the menus to the matchbooks.



Dirty French

CARBONE

Saddle's
COCONUT GROVE

275 MULBERRY STREET

CARBONE
PRIVILEGE

Terrisi

Saddle's
COCONUT GROVE

Italian

- PROSCUITTO & MELON 29
- WHIPPED RICOTTA, GRILLED BAKED 22
- TRUFFLE PASTA 28
- LOCAL GOAT CHEESE 24
- HOMEMADE MOZZARELLA 26
- ROBIOLA 27

Pasta

- TRUFFLE PASTA 28
- LOCAL GOAT CHEESE 24
- HOMEMADE MOZZARELLA 26
- ROBIOLA 27

Meats

- PROSCUITTO 15
- SOPPRESSATA PICANTE 22
- MORTADELLA 14
- FINOCCHIONA 17

Secondi

- CHOPPED SALAD 19
- SQUASH CARRACCIO 22
- BABY KALE 10

Contessa

SALUMI

- PROSCUITTO SAN DANIELE 15
- MORTADELLA ENILIANO 14
- SPECK ALTO ADIGE 17

ANTIPASTI

- DAILY IMPORTED BURRATA 20
- OCTOPUS AGRODOLCE 31
- TONNATO CRUDO 27
- CHIANINA BEEF CARRACCIO 31
- CALAMARI MARCO 28
- MEATBALLS ALDO 22
- WHIPPED RICOTTA 10
- EAST COAST OYSTERS 24

PRIMI

- CHOPPED SALAD 19
- SQUASH CARRACCIO 22
- BABY KALE 10

**“A LUST FOR
EXCESS AND AN
INSTINCT
FOR SHEER
ENTERTAINMENT”**

-THE NEW YORK TIMES





THE FIRST REVIEW THAT CHANGED EVERYTHING

Carbone's fate as a generation-defining restaurant was sealed just three months after it opened for business. In June 2013, the *New York Times* gave it a three-star review, highlighting the dining experience as one filled with "sheer entertainment that makes a lot of other restaurants seem like earnest, unimaginative drones."

D8

THE NEW YORK TIMES, WEDNESDAY, JUNE 5, 2013

RESTAURANTS | PETE WELLS

A Red-Sauce Joint Steals the Show

Like a Tarantino film, without the shooting and bad language.

AT CARBONE, THEY DON'T ASK if you've dined with them before. Even if you haven't, the answer would still be yes. This is supposed to be the Italian restaurant where you celebrated your birthday before anyone told you that ennio scarpariello isn't Italian.

This being 2013, and the two chefs, Rich Torrisi and Mario Carbone, being former sous-chefs of Marco Baisani and Daniel Boulud, Carbone is infinitely more self-conscious than those old restaurants. It is a fancy red-sauce joint in Greenwich Village, as directed by Quentin Tarantino, bringing back the punch-in-the-guts thrill of a genre that everybody else sees as uncultured and a little embarrassing, while exposing the sophistication that was always lurking there. Carbone has a technical prowess that can make you giddy; a lust for excess that can, at times, make you a little queasy; and an instinct for sheer entertainment that makes a lot of other restaurants seem like earnest, unimaginative drones.

There are, in the Tarantino style, funby film allusions: the tile floor from "The Godfather," the narrow passageway into the back dining room that makes you feel like Ray Liotta handshaking his way into the Copacabana.

There are the songs that make you think, "Oh, no," followed by "I forgot how great this is," as people with open bottles of Saja on the table drum their fingers to "We Open in Venice."

Like Tarantino's love letters to pulpy exploitation films, Carbone affectionately picks up the clichés of his genre, winks them, then burles them at your head. Our captain wears a B-boy's smile and a tuxedo in a shade of maroon last seen at Liberace's estate sale. Bearing a hollowed-out wheel of Parmesan, he stabs a nugget of cheese and slides it on to my plate. It tastes young, milky and uninteresting, but most come peppy slices of smoky and complex aged country ham. Kentucky serving as a stunt double for Parma, and a stack of "grandma bread," a no-cheese Sicilian pizza with oregano and a shadowy, sweet pulp of tomato sauce. Both make me smile.

More unbidden genre tropes are on the way: tart giardiniera in oil, amazing garlic bread, fried ribbons of dough under powdered sugar, sautéed fig grapes, and delicate house-made limoncello in a bottle furry with frost. I don't love every one of these extras, but I love the way they make me abandon any hope of quiet moderation.



The classic styling and interior of Carbone, an Italian-American restaurant in Manhattan, make it an ideal location for featured players like the table-side Caesar salad, left, and the Carbone scampi.

Nearly the entire menu at Carbone is a quotation, starting with the \$50 veal parm, which is larger than some fancy brick-oven pizzas and looks like one, too, with ovals of browned buffalo mozzarella and a bright red, summer-fresh, barely cooked tomato sauce. Served with a fried shaft of bone, it's a shock-and-awe dish, and the most shocking thing about it is that there is no real revisionism here; it is a veal parm, the way you always hoped it would be.

More often, the old tropes get an injection of technique that acts like a syringe of spinghiano plunged into the heart. The two-and-a-half-pound lobster fra diavolo is both brash and polished, the huge portion galvanized by Calabrian chiles and soothed by Cognac. No shrimp scampi has been handled as gently or luxuriously as Carbone's chorus line of langoustines, claws extended, bodies split and slick with butter that implies garlic without coming right out and saying it.

Concentrated shellfish stock is the foundation a zuppa di pesce so deeply fragrant, you know it's coming before it's on the table.

I wish the clam broth that infuses linguine vongole had the same intensity. But other plates of what Carbone calls "macaroni" are remarkable. Knuckles of tortellini stuffed with whipped sheep's milk ricotta are a show of zero-gravity delicacy while cubes of rigatoni are forceful and substantial, their tomato sauce unabashedly spicy and slyly buttery.

There are also, in this movie, some lapses in taste and judgment. Fried brocc-



CARBONE ***
181 HUNTER STREET (BLEECKER STREET), (212) 254-0878
CARBONE.NY@NYT.COM

Atmosphere Both formal and fun, in a way only upscale joints can be.

Service Are these genuine old-school Italian waiters, actors playing a role or both?

Sound level Like everything else, slightly heightened.

Recommended Carpaccio piemontese, scampi alla scampi, polipo pan tost, Caesar salad alla Z, tortellini al rasi, arcy rigatoni vodka, baci di ricotta, lobster fra diavolo, doukita lamb chop, cherry pepper ribs, lemon chioscaccia, carrot cake.

Drinks and wine Perked cocktails (vintages, mid-ton) are primarily updated; the list of French, Italian and American wines is strong, though there are no bottles under \$60.

Prices Antipasti and other starters, \$14 to \$36; pastas, \$19 to \$23; main courses, \$30 to \$52 and up.

Open Daily for dinner.

Reservations Accepted. Dining room and accessible restroom are on street level.

What the stars mean Ratings range from one to four stars and reflect the reviewer's opinion primarily to food, with ambience, service and price taken into consideration.

it rabe is locked inside some of the heaviest, greatest batter I've ever tasted. Carbone's drumstick, a wedge of layer cake with mascarpone between Marsala-soaked spongecake, is too wet and too boozy, a case where the middlebrow original is better than the highbrow makeover.

Strangest of all is something called Chinese chicken, which tastes as if Mr. Torrisi and Mr. Carbone were trying to recreate something from Chinatown Night at their college cafeteria. But old Italian-American restaurants generally have at least one dish on the menu that nobody orders. Maybe this soy-and-sesame-seed nonentity is supposed to be another in-joke, although it would be funnier if, when you ordered it, your captain said, "We just sold out."

They could get a laugh out of it, too. Carbone's captains are character actors who have mastered the jokey, swaggering, slightly bossy style that was a New York specialty before waiters began to have the blandly pleasant manners of the young people who carry Bibles and ring doorbells on Saturday mornings. There is a flash of three-card monte below the surface, as these men sell you on meatballs with your pasta or promise that the lemon chioscaccia is "the best you'll ever have in your life." They aren't lying about the chioscaccia, though.

And the most talented among them can improvise dialogue while grating creamy ricotta salata over a Caesar salad that is just as sharp with anchovies as you could wish. One night a star of romantic comedies was sharing one appetizer and one main course with her male date. When the date left the table, the captain leaned in.

Captain: Nice catch.

Star: Excuse me?

Captain: I said that's a good-looking young man you're with.

Star: (Raucous laughter.)

This kind of thing is funny only if you agree to play along. And I'm not ready to play along with all of Carbone's casting decisions: currently all the captains, typically the most highly tipped employees, are men.

But I admire nearly all the other choices that Mr. Torrisi, Mr. Carbone and their business partner, Jeff Zalaznick, have made. Many American restaurants are trying to reinvent fine dining by looking abroad. Carbone is mining the best elements of homegrown American style of service and cuisine that flourished when men in ties and women in heels, woozy from a final shot of sambuca, wobbled to the sidewalk-clutching doggy bags.

We didn't know how good we had it. Carbone is here to remind us.

Off the Menu | FLORENCE FABRICANT



HEADLINER Distilled
The name misleads a bit. Though Distilled is supposed to evoke an old-time public house, it's much more than that, what with Shane Lyons (above), who was at Momofuku Noodle Bar, as the chef and a partner, serving updated American classics. "We want this to be fun," Mr. Lyons said. He plans to offer chicken fried duck with waffles made like French toast; pork ribs with watermelon; and an apple pie soda float. And for

HUNGRY CITY | LIGAYA MISHAN

Revel in the Roar of the Crowd

Maison Premiere graduates from absinthe and oysters.

THE TIGHT ROOM is astonishingly loud, verging on raucous, but still the waiters murmur, hands behind their backs.

They are better dressed than the diners, in black vests and narrow ties, and never break character. A porcelain cloche is lifted, a sauce poured from a tiny jug, cloche after cloche, jug after jug. At first this prim choreography seems tongue-in-cheek, then earnest, and finally almost silly — and all the more charming for it, like much of the understated seduction that is a night at Maison Premiere.

When it opened in Williamsburg, Brooklyn, two and a half years ago, Maison Premiere was an exercise in mood (louche) and epoch (French Quarter circa the 1890s). Primarily a bar, it served little



**MASTER TAILOR
ZAC POSEN KNOWS BEST**

No detail is overlooked at MFG, where captains at Carbone are specially trained in old-school hospitality and dressed to the nines in three-piece tuxedos rendered in sharp lines and lush tones — designed by none other than Zac Posen.

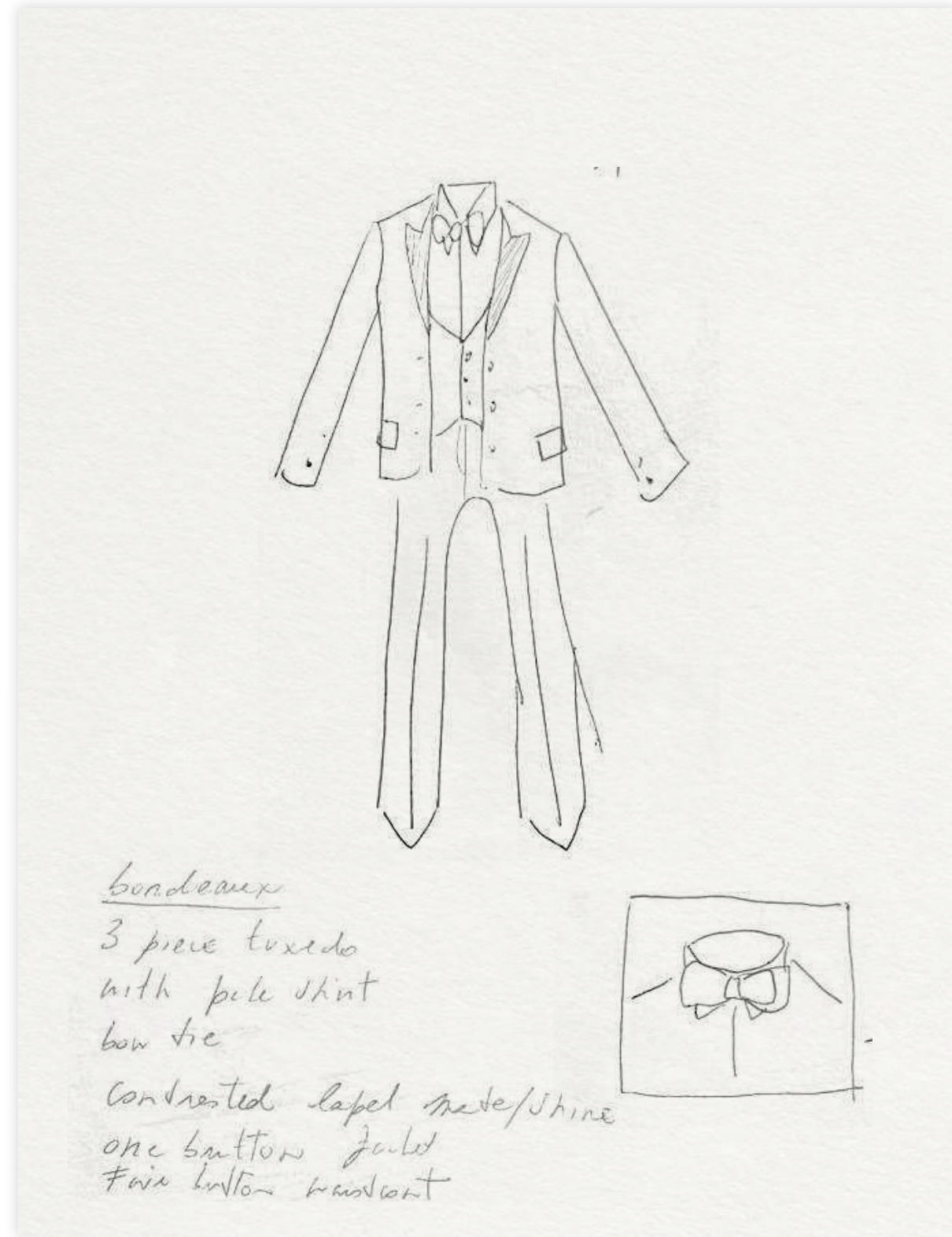

CARBONE PRIVATO

New York, NY

At Carbone's members-only club in Hudson Yards, not only the plates are custom. Guests can order any dish off the menu — including favorite standards and beloved family recipes.



TORRISI

New York, NY

At Rich Torrisi's reconception of MFG's first restaurant, vintage Ginori plates play off the historic Puck Building's vaulted ceilings and arched windows.



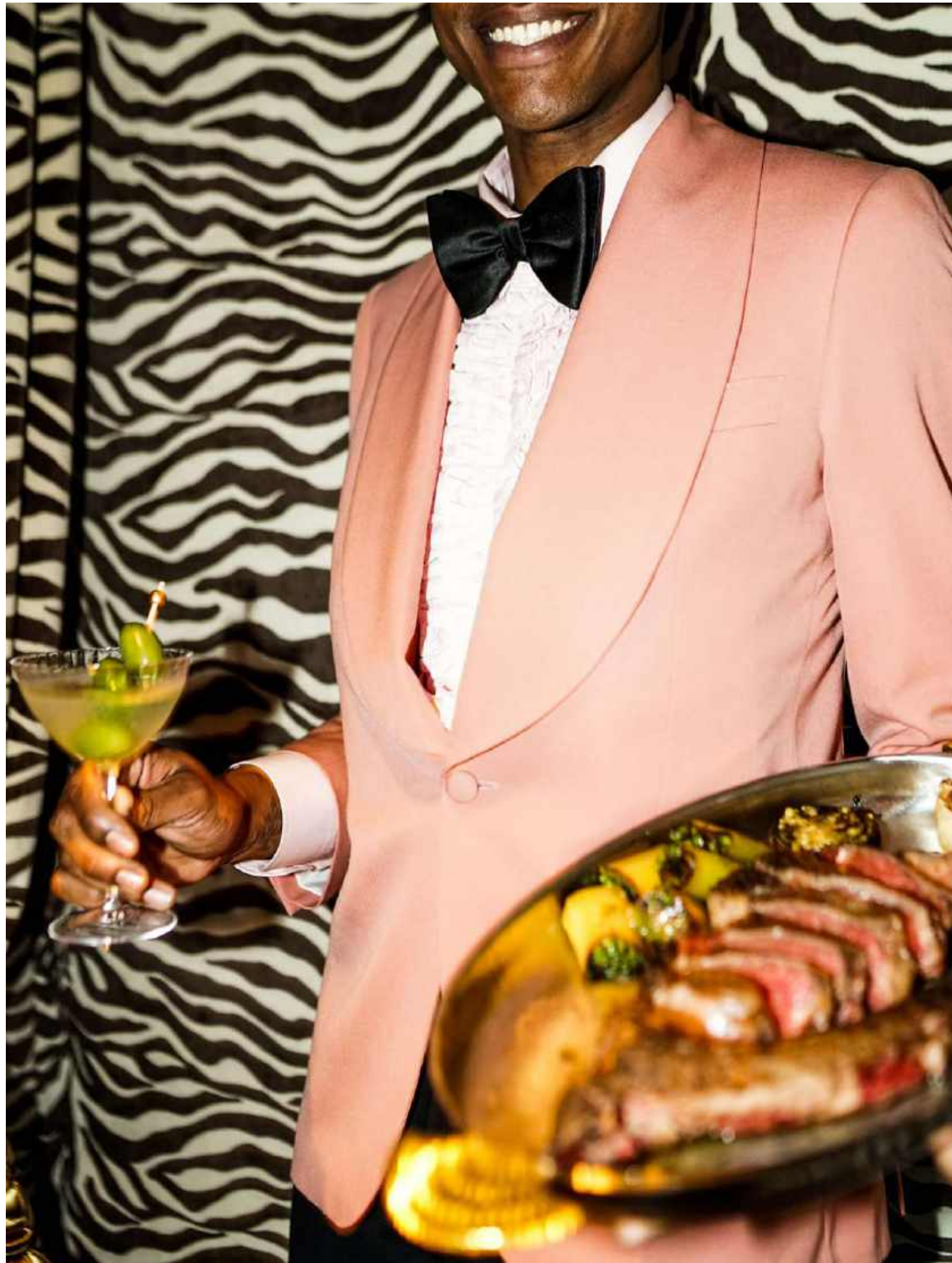

SERVICE WITH A TWIST

Before Carbone opened in 2013, Major Food Group's partner Jeff Zalaznick assembled the waiters, also known as captains, and put them through something of a boot camp to practice the art of swanky hospitality, recalling another era of fine dining when waiters had a swagger, authority and dry humor that is

rarely seen in restaurants today. Today, their impeccable, attentive service is central to the entire experience of dining out with Major Food Group. Carbone's captains, dressed sharply in velvet tuxedos, have become characters in what can sometimes feel like a theatrical dining experience, dropping quips as they toss Caesar salads or layer veal parmesan table-side or appearing with a wheel of Parmesan. Tablecloths are always white and crisp. Plates are always presented exquisitely. The experience is always as vivid as the food. That's the Major Food Group way.

At Carbone, captains often give dishes a final twist at the table, a beloved tradition that separates the dining experience from any other in fine dining.





This private residence, designed by Vicky Charles, is emblematic of the designer's love of lush materials, warm tones and lived-in textures.

REMIXING GRAND ROMANCE WITH CHARLES & CO

one as it is an emotional one. Perfection bores her. Charles embraces charming flaws, knowing that homes are the ultimate stages for active lives and need space to breathe and evolve over time. No wonder high-profile private clients like George and Amal Clooney, Emma Stone, and Harry Styles have relied on her to translate their personal tastes into imaginative, eclectic interiors where functionality is never sacrificed for form.



For her efforts, Charles has become one of the most sought-after designers from London to Hollywood, balancing modern and traditional pieces to create timeless, ease-inducing spaces that exude an intangible sense of belonging and live-able sophistication.



If you've ever stepped inside a Soho House, you've probably seen the work of Vicky Charles come to life in the club's lush but lived-in atmosphere. The lauded designer lent her vision for exceptional spaces to the exclusive members club for more than a decade before launching her own boutique firm in 2016 where she specializes in a range of hospitality spaces and private residences. While she is known for mixing a laidback glamour with an English country house style, her signature is not as much an aesthetic

With the Villa Miami spaces and residences, Charles is creating a uniquely European sensibility with noble materials, rich tones and historic inspiration reinterpreted for today. Custom floor patterns of entwining marbles and natural stones run throughout the building, and each residence is wrapped in welcoming, natural materials to complement the glass walls and stunning amount of natural light entering. The result is romantic and warm, unlike anything else in a city defined by white marble and chrome.



La Marchande Restaurant Dining Room, NYC



East Hampton, NY



Alpaga Megeve, France



Barcelona



Brooklyn Heights Brownstone, NY



Beverly Hills, LA



La Marchande Restaurant, NYC



Enzo Enea's gardens are designed to dialogue with art and architecture, a synergistic collaboration displayed in this private client's garden.

CULTIVATING A LUSH SENSE OF HARMONY WITH ENZO ENEA

clients have included the wife of the King of Bahrain, the Mandarin Oriental in Beverly Hills and the Peninsula Hotel in London. Along the way, Enzo became a prodigious collector of plants. In 2010, he turned his collection of trees, some of which are more than 100 years old, into the world's first Tree Museum near his headquarters in Switzerland, in Upper Lake Zurich, on land leased from a nearby convent. The museum is open to the public and welcomes more than 30,000 visitors a year.



From private spaces to public promenades, Enea always approaches with the same overarching philosophy: experiential green spaces composed of native plants, in beautiful conversation with the surrounding landscape. Creating a layered experience and story from the undergrowth to the canopy heights, his work can be likened to painting or composing with greenery with living layers complementing each other and coming in and out of bloom year round.



For Italian landscape architect Enzo Enea, a career in gardens was arguably destined from birth. He comes from a long line of Italian stonemasons and grew up helping his grandfather build outdoor fountains. And he got his start when he joined his father's business decorating gardens with stone and terracotta in the early 1990s. Today, Enea's namesake firm designs imaginative but contemplative green spaces for hotels, churches, residences, and public spaces all over the world, from Miami to Zurich, New York City to the Greek island of Kea. His

Enea's design approach prioritizes integration, not decoration, responding to the unique factors of every project, from the micro-climate to the architecture. Today, he is especially known for his work in Miami, where he has a satellite office, and where his synergistic approach can be found throughout the Villa Miami grounds.



Private Garden, Switzerland



Private Garden, Switzerland



Private Garden, Italy



Enea Garden Lounge, Miami



Tree Museum, Rapperswil-Jona, Switzerland



Private Home, Switzerland

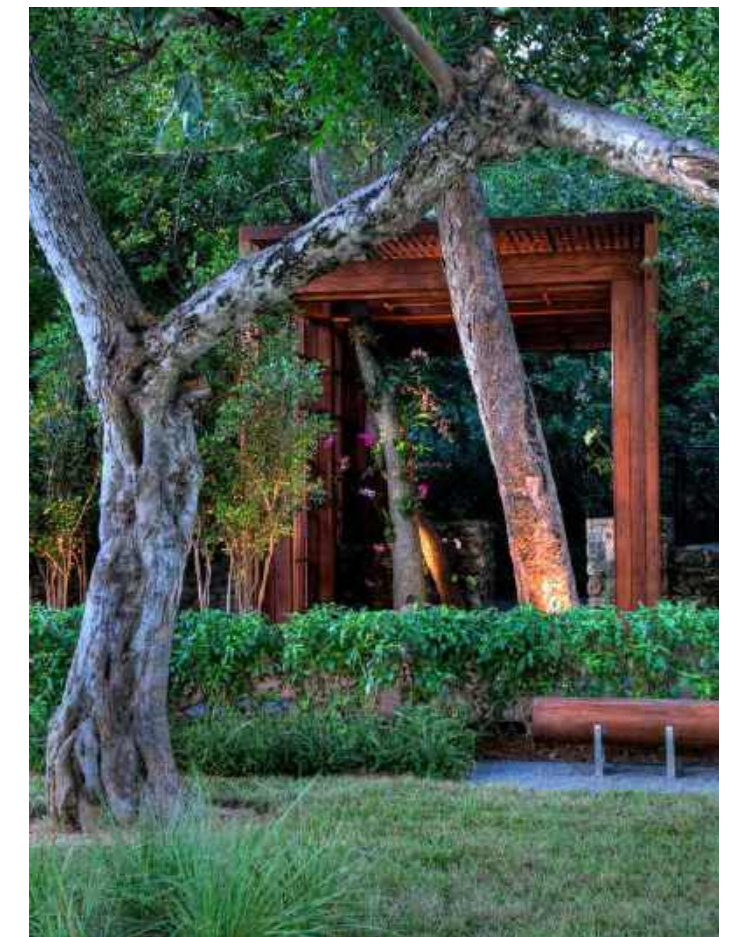

Simpson Park, Miami



ODP is behind many of the most anticipated projects in Miami, including the interconnected supertall towers in Brickell, designed with Foster + Partners.

REENVISIONING THE MIAMI SKYLINE WITH ODP ARCHITECTS



Since its inception, O'Donnell Dannwolf & Partners—helmed by founder and president Kurt Dannwolf—has practiced a holistic, full-service approach to architecture in Florida. An ODP project goes beyond specs and budgets to consider the history of the site,

the current state of play with materials and sustainability, and the emotions of the new building's inhabitants.

In his nearly 30-year career, architect Kurt Dannwolf has created some of the most recognizable skyscrapers in Southern Florida, including the Four Seasons Hotel & Tower in Miami, the Dacom Headquarters in Korea, and the Telecom Headquarters in Buenos Aires. His firm, ODP Architecture and Design, is also a frequent collaborator with international visionaries with special projects in the region. Dannwolf served as the architect of record for the award-winning One Thousand Museum luxury tower, the last building designed by the late British architect Zaha Hadid, and the Towers at 1201 Brickell, designed by Fosters & Partners, among many other projects. Today, ODP has offices in Hollywood, Florida, as well as Fort Lauderdale and Tampa, and is recognized as an expert in Floridian waterfront living.

ODP's work spans genres, ranging from cutting-edge commercial work for the likes of Apple, to public works and lush private residences. The principles that define ODP Architects' design ethos—dynamic problem-solving and a holistic interpretation of how life is best lived—most often coalesces around Miami's new high-rise residential buildings. One Thousand Museum, One Bayfront Plaza II, and now Villa are redefining architectural excellence in Miami.



Surfside Seaway, Florida



Surfside Seaway, Florida



One Thousand Museum, Florida



1201 Brickell, Florida



Paramount Miami Worldcenter, Florida



Terra developed another landmark bay-front project, Park Grove, which opened in 2018. The striking Rem Koolhaas-designed towers have helped redefine Coconut Grove, one of Miami's oldest neighborhoods, as a dynamic creative community.

PLACEMAKING & COMMUNITY BUILDING WITH TERRA

After the 2008 financial crisis, the younger Martin pivoted his approach to development and has since established a reputation for embracing a “less is more” approach, considering the history, surrounding public space, infrastructure and density of the places where he invests and taking a long view to urban development.

Under Terra's stewardship, Miami neighborhoods such as Coconut Grove — and now Edgewater — have evolved into newly vibrant communities complete with luxury residences, world-class dining, and active art scenes. When developing a building, the team approaches with the intent of transforming and improving life for the surrounding residents, not simply the building's inhabitants, whether this means cultivating public parks and gathering spaces, improving the streetscape, or creating opportunities for retail and dining to flourish nearby.



David Martin is the kind of developer who doesn't just think about buildings, but about neighborhoods. Born and raised in Miami, Martin founded Terra in 2001 with his father, a banking and real estate corporate attorney.

Today, Terra counts about 100 employees and more than \$4 billion developed since the firm began, often the fruits of partnerships with the world's most prestigious architects and designers. Projects include a diversified mix of residential, commercial, multi-family and mixed-use developments — including Five Park, Mr. C Residences, Grove Central, Miami Beach Convention Center Hotel, Upland Park and Natura Gardens — that are recognized both for their inspired designs and their positive influence on the communities that surround them.



Grove at Grand Bay



Mr. C Residences



Mr. C Residences



Five Park



87 Park



Park Grove



87 Park



Five Park



At Regalia, the Sunny Isles luxury condominium tower co-developed by One Thousand Group's Kevin Venger, each floor is lined by undulating verandas that give the building its distinctive shape.

SCALING THE NEW MIAMI WITH ONE THOUSAND GROUP



“Real estate developers are the new curators.” That’s the mantra behind the newly formed One Thousand Group — a partnership between Louis Birdman, Kevin Venger and Michael Konig — signaling their ambitious vision for the future of Miami as a global city on the brink of a new chapter of expansion. Their namesake project is the historic and award-winning One Thousand Museum,

which opened on Biscayne Boulevard downtown in 2019. The 62-story building is the last project from the innovative mind of Zaha Hadid, the late Iraqi British architect known for her futuristic designs and curving façades. One Thousand Museum is one of the most complex skyscrapers ever built and has become an iconic symbol of the rapidly changing Miami skyline.

In recent years, Venger and Birdman, two of the developers behind One Thousand Museum, joined forces with Michael Konig to tackle a range of world-class buildings in prime locations across the city. The trio brings together decades of experience across innumerable residential and commercial projects. Venger co-developed the oceanfront ultra-luxury condominium tower Regalia and Paramount on the Bay in Edgewater. His other projects include the Ten Museum Park Condominium and the Four Seasons Hotel and Tower Miami. Birdman, an architect by training, has developed dozens and dozens of projects nationwide, including Emerald Brickell, Vue on Brickell and Davinci Coral Gables in the Miami area. Finally Konig, whose career includes stints in finance and marketing, developed 1110 Brickell Avenue, 1680 Michigan Avenue and 11900 Biscayne, among many other projects. With Villa Miami, One Thousand Group is expanding its deepening its investment in Edgewater, a neighborhood uniquely positioned to relish in the dynamism of the city now and in the years to come.



One Thousand Museum



Regalia Miami



Regalia Miami



One Thousand Museum



One Thousand Museum

02

EDGEWATER: COASTAL GEM

**THE HEART OF NEW MIAMI — ANCHORED BY
SPRAWLING PARKS, THE SPARKLING BAYFRONT, AND
MIAMI'S FINEST ARTS, CULTURE & DINING.
THIS IS A NEW KIND OF WATERFRONT LIVING.**



Miami is a city of rich history defined by key phases of rapid change. The 1980s saw the rise of Miami Beach, filled with characters from the fashion and entertainment worlds. During the aughts, the city witnessed the birth of Art Basel, establishing Miami as a mecca for art. Now, the city's next transformation is emanating from Edgewater, the bayfront district beloved for its sprawling parks, waterfront views, thriving restaurant scene and ultra-convenient location.

In many ways, Edgewater encapsulates the changes sweeping Miami in recent years. The city has emerged as a hub for a new type of global citizen, drawn here by more than just the famous beaches and nightlife, but by

the city's wholly unique waterfront lifestyle. Here, a diverse community is putting down roots, thriving and investing in the future of the city. Edgewater is ideally situated for Miami's next era, located next to the Design District and abutting the Wynwood Arts District. And it's just a drive over the Venetian Causeway from Miami Beach. Edgewater is also home to some of the city's most exciting restaurants, as well as the revitalized Margaret Pace Park and cultural destinations like the Institute of Contemporary Art Miami. The arrival of Villa Miami only confirms a movement that has been building for years: Edgewater is no longer one of the city's best-kept secrets. It's the center of the Miami of today and tomorrow.

Cocktails are a prized specialty at ZZ's Club, a members-only fine dining destination in the Miami Design District, minutes from Edgewater.

**A WHOLE NEW SIDE
OF MIAMI**

Edgewater's edge is its location, right in the center of the New Miami — minutes from downtown and the design district, adjacent to Wynwood and just across the Venetian Causeway from Miami Beach.

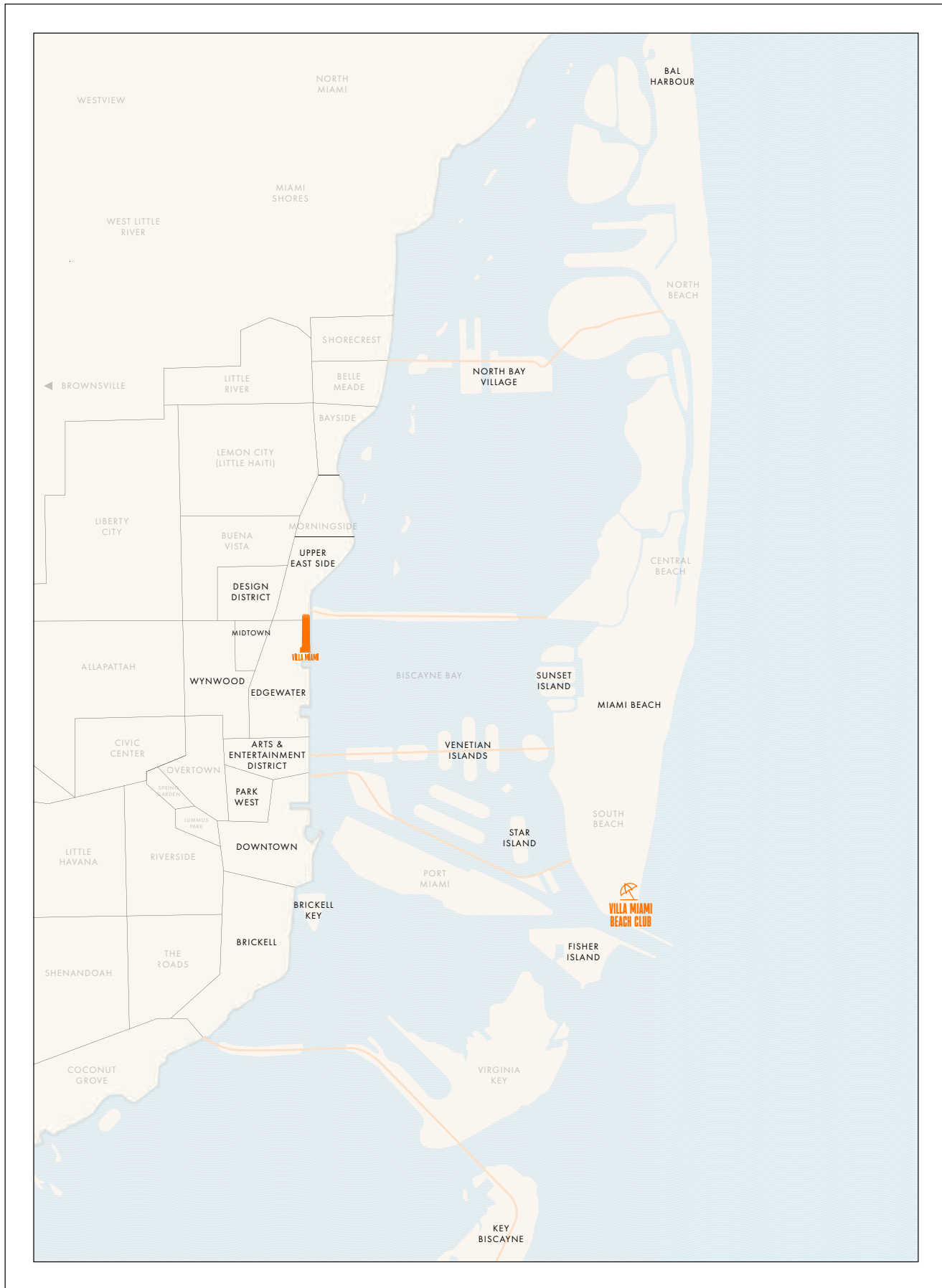

“

**THERE'S AN AMAZING
ENERGY HERE, A
GROWING MOMENTUM
IN ALL DIRECTIONS —
DINING, ART, AND
CULTURE, ALL ON THE
BAYFRONT**

DAVID MARTIN

”

**A WHOLE NEW SIDE
OF MIAMI**

The neighborhood is perched on the edge of the bay, dotted with waterfront parks and marinas that give this area its unique blend of city energy and waterfront ease.



HOME GROWN INGENUITY

Edgewater sits alongside the city's most exciting restaurants, like ZZ's Club (left), a sumptuously decorated dining club only outshined by its menu, and Michael's Genuine (right) a neighborhood favorite for seafood.



THE BEST SPACES & PLACES IN EASY REACH

After exploring the sprawling parks and sparkling bayfront, head to the city's sleek shopping districts and cultural centers. There's no shortage of the best of art, culture and dining to explore here.



The heart of the neighborhood is Margaret Pace Park, a tucked-away oasis for joggers, dogs and families.

Every performance thrills at the historic Adrienne Arsht Center.



The Design District is the city's most sophisticated shopping district and a playground for outdoor sculptures.



ZZ's Club's avocado caviar combination gives a new meaning to the word rich.

Get a hypnotic glimpse below the waves without ever setting foot in the Atlantic at the Frost Museum of Science.



The headquarters of YoungArts is one of Miami's most beloved buildings, a stained-glass "jewel box" that is a historical landmark.



ALEXIS is a high-end womens-wear line, offering contemporary collections that speak to the modern woman.

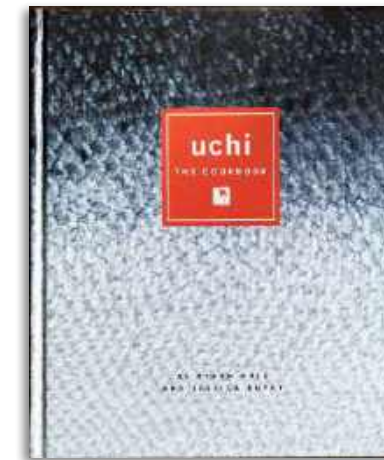

At Uchi Miami, the city's award-winning sushi restaurant, the service is as impeccable as the presentation.



At the Design District's Contessa, Bistecca Fiorentina is cooked to perfection and crowned with aromatics.

BEYOND THE BEACHES

ARTS

- 1 De La Cruz Collection
- 2 ICA Miami
- 3 Rubell Museum
- 4 YoungArts
- 5 Gary Nader Art Centre
- 6 Opera Gallery
- 7 Perez Art Museum
- 8 David Castillo Gallery
- 9 Christie's

DINING & BEVERAGE

- 10 Baccarat Cafe
- 11 Contessa
- 12 ZZ's Club
- 13 Aubi & Ramsa
- 14 Dior Cafe
- 15 Michael's Genuine
- 16 Cote
- 17 Double Knot
- 18 Itamae
- 19 Latelier Joel Robuchon
- 20 OTL
- 21 Sofia
- 22 Swan
- 23 Uchi
- 24 Hiden
- 25 Haiku Wynwood
- 26 The Salty
- 27 Pastis Miami
- 28 Zak the Baker
- 29 Amara at Paraiso
- 30 Klaw
- 31 Little Hen
- 32 Pura Vida
- 33 Rima
- 34 Chimba
- 35 Ossobuco
- 36 Sagrado Cafe
- 37 Astra
- 38 Maty's
- 39 Casadonna

PARKS & GREEN SPACES

- 40 Margaret Pace Park
- 41 Bay Park
- 42 The Baywalk
- 43 Maurice A. Ferré Park
- 44 Biscayne Park
- 45 Roberto Clemente Park

ATTRACTIONS

- 46 Frost Museum
- 47 Adrienne Arsht Center
- 48 Kaseya Center
- 49 Wynwood Walls
- 50 Palm Court
- 51 Miami Symphony Orchestra
- 52 Haitian Heritage Museum

RETAIL & SHOPS

- 53 Alexander McQueen
- 54 Prada
- 55 Lanvin
- 56 Gucci
- 57 Bottega Veneta
- 58 Chanel
- 59 Celine
- 60 Loro Piana
- 61 Loewe
- 62 Louis Vuitton Mens
- 63 Hermes
- 64 Kith
- 65 Tom Ford
- 66 Warby Parker
- 67 Trader Joes
- 68 Aviator Nation
- 69 Mercato Miami
- 70 Glottman
- 71 Whole Foods (Coming Soon)

HEALTH & WELLNESS

- 72 Jetset Pilates
- 73 The Sacred Space Miami
- 74 IGK Salon
- 75 Ahana Yoga
- 76 Dr Barbara Sturm
- 77 Mimi Yoga
- 78 Anatomy Gym

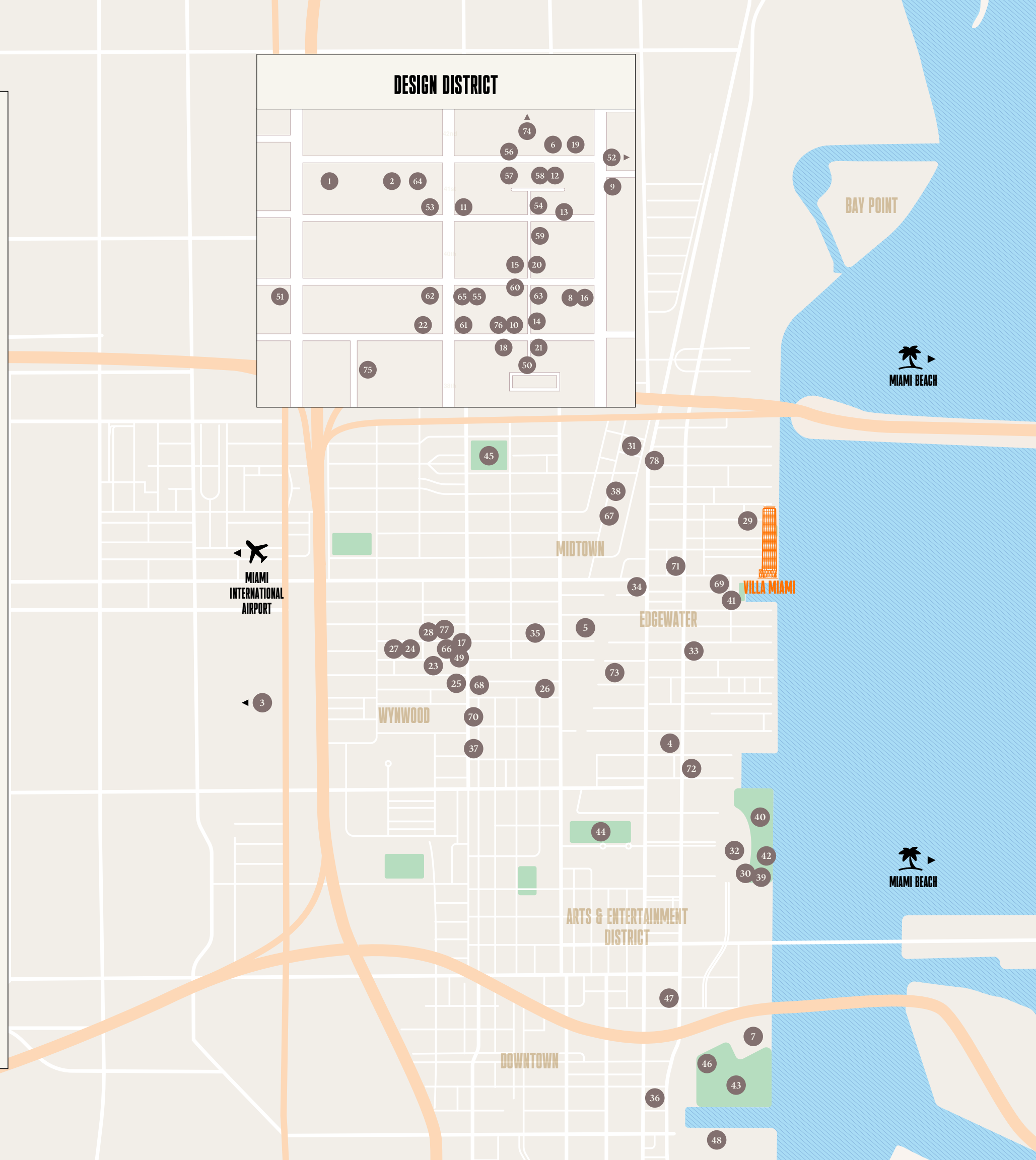
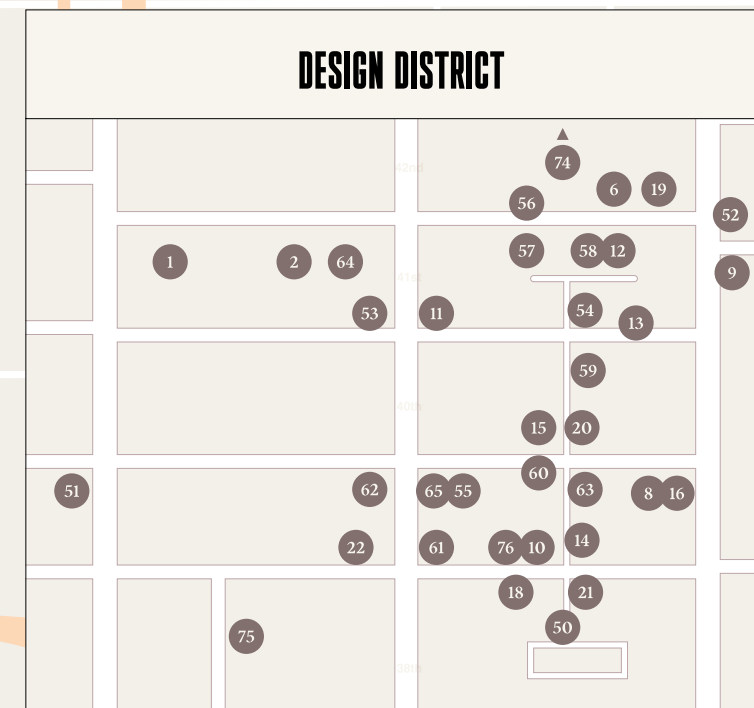

ART & SOUL

The Institute of Contemporary Art, also known as ICA, is a contemporary art museum located in the heart of the Design District. ICA is renowned for its vigorous embrace of new mediums and underrepresented artists, locally and internationally.





A HOME FOR THE ARTS

The Rubell Museum's collection of contemporary art from the 1960s onward is filled with daring, controversial works from superstar artists such as Tesfaye Urgessa, whose painting *"Let Go Of Your Claim on Me I"* was acquired in 2022.

IN PURSUIT OF STYLE

The Miami Design District is more than an 18-block neighborhood with more than 150 stores. It's one of the most exciting shopping districts in the world, renowned for its breadth of luxury stores, innovative architecture and colorful outdoor art installations.





**WHERE LUXURY
CALLS HOME**

The design district is a playground for fashion obsessives, featuring outposts from every major and minor luxury house from Gucci to Dior.

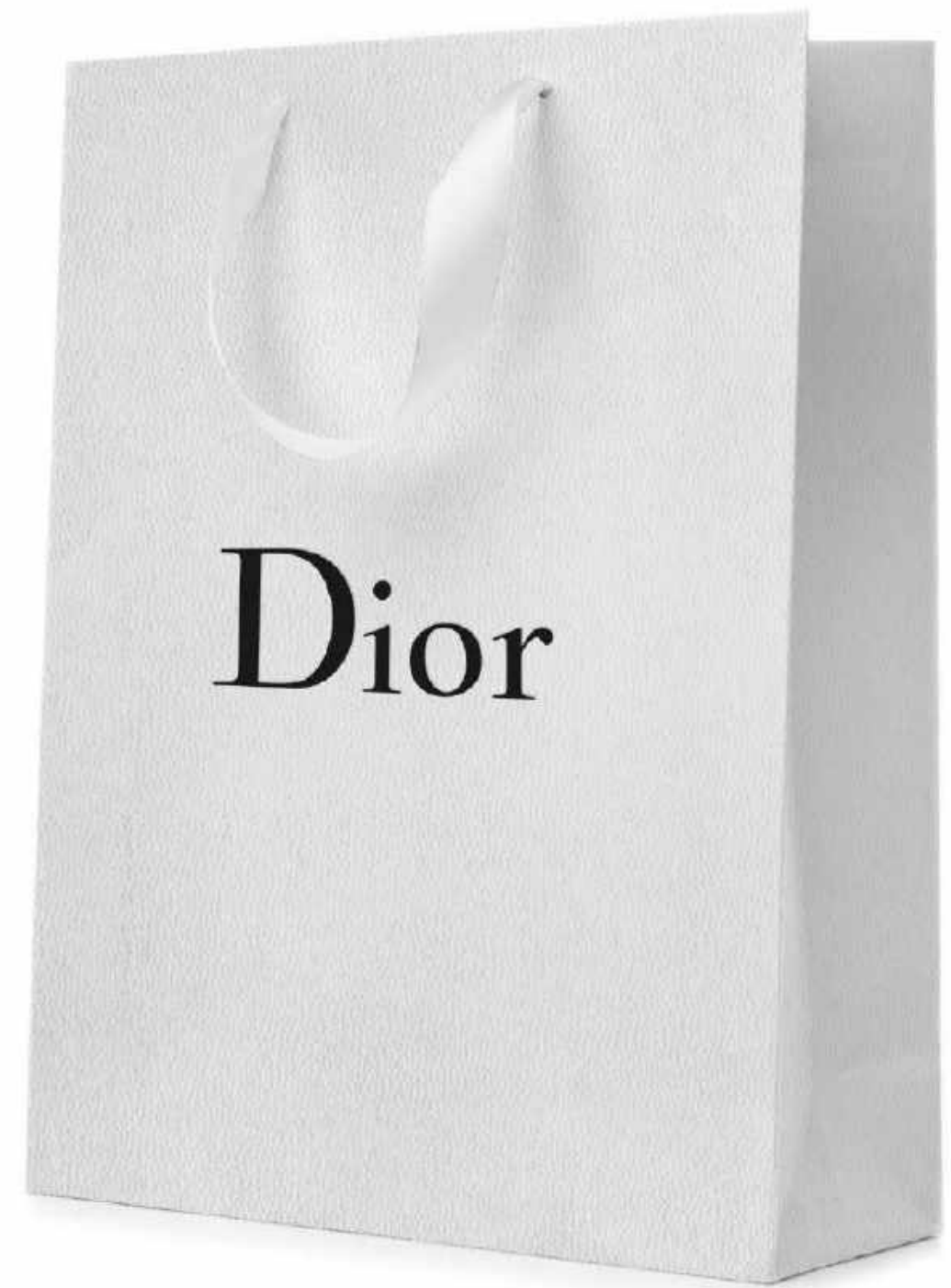

**A NEW STANDARD FOR
CULINARY EXCELLENCE**

The trout roe toast is a signature classic at ZZ's Club, where the highest-quality ingredients are regularly flown in from Tokyo.



MIAMI'S BEST DISHES

Many of Miami's most exciting restaurants can be found in and around Edgewater, a dynamic neighborhood poised to transform the city and set the stage for its latest evolution as a global destination for fine dining and culture.

Diners are spoiled for delicious choices at Uchi Miami, an award-winning sushi restaurant.



Across the range of Miami's culinary destinations, it's more than just food -- it's an artform.



Contessa transports guests to old-world Lake Como with its perfectly crafted pastas.

Those who want to try the entire Uchi menu can opt for the 10-course chef's tasting or a six-course signature tasting.



Trout and pomegranate are the unlikely fish/fruit duo you never knew you needed -- good thing Uchi did.

Contessa has no shortage of reinvented takes on classic dishes -- including their squash carpaccio.



Don't be intimidated by the whole crab at Klaw, it's worth the work.



Dive into high-end Japanese restaurant ZZ's Club, with ingredients flown in fresh from Tokyo.



Indulge in a sweet treat (or two, or three) from Wynwood staple Zak the Baker.



03

AMENITY DESIGN

**AN ARRAY OF SPACES TO SUIT ANY OCCASION, PARTY,
EVENT, WISH & WHIM**

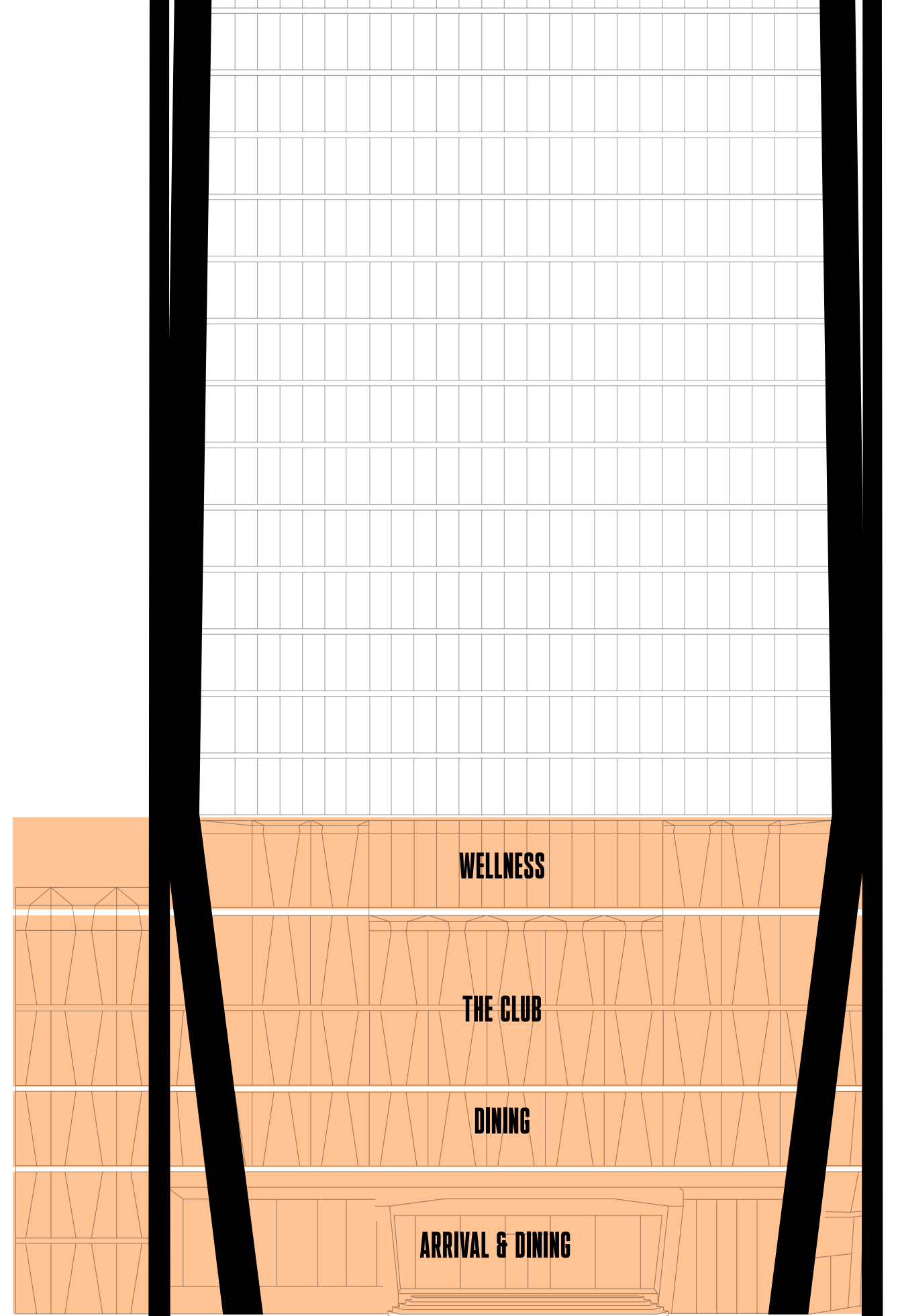

At Villa Miami, the first five full floors are dedicated to shared and private spaces for everything from exceptional dining to state-of-the-art fitness training.

FROM THE ITALIAN COAST TO MIAMI'S SHORES

A Slim Aarons photograph of a young Henry B. Cabot, taking a drag of a cigarette while sailing off the coast of Boston with his family in the 1950s. A seagull taking flight above some docked gondolas in Venice with the stately Basilica of San Giorgio in the background. A pensive Yves Saint Laurent sunk into an orange sofa in his home in Sardinia in the 1970s.

These are just some of the images that were on the mind of designer Vicky Charles as she embarked on creating an aesthetic vision for Villa Miami that imbues a rich intensity unlike anything else in a city long defined by Art Deco, white marble and chrome.



Designer Vicky Charles spent more than a decade designing exceptional space for Soho House, and is now one of the most sought-after interior designers from London to Hollywood.



Charles chose materials with rich histories, like textured Zellige tiles, that transform interiors into artisanal worlds.

Instead, Charles looked to coastal European cities, where the romance of the water's edge merges with a cosmopolitan sophistication. Villa Miami's interiors reflect the languid glamour of those towns. There, style is infused in even the most quotidian of daily rituals and the traditions of food and family are celebrated regularly.

Charles also took cues from the ornate Milanese estate Villa Necchi Campiglio, built in the 1930s and designed by Italian architect Piero Portaluppi. The home quickly became the party spot of its time, dazzling guests with the austere glamour of its patterned travertine and marble floors and private outdoor pool, a rarity in those days. Today, the villa is considered an icon of Italian rationalism, beloved by design enthusiasts for its embrace of contrasts, mixing classicism with modern architecture. It has appeared in films such as "I Am Love" and "House of Gucci."

With these references in mind, Charles prioritized hefty materials with integrity and grit like wood and granite, but arranged in timeless shapes and clean lines that serve as a canvas for the many lives that will take shape within the Villa Miami's

walls. The throughline is a deep warmth in color, materials and design that create otherworldly spaces. A green, brackish travertine is transformed into an intricate pattern Villa Miami's sprawling lobby floor, connecting grandeur of the building's exterior with the the Italian-inspired glamour of its interiors. Heading upstairs, full-bodied tones in leathers, stones and grass cloth evoke a refined spirit of relaxation and indulgence throughout the club's great room, private dining areas and plush screening room. These spaces are designed for both celebrations and quiet conversations, for sinking into the comfort of a place that feels both nostalgic in its familiarity but modern in its ingenuity.

In Villa Miami's pool deck and spa, inspired by the thermal spas on the Italian island of Ischia, rich greens and browns give way to milky whites and soft aquas, a palette chosen to respond to Miami's natural light and imbue a serene tranquility. On the pool deck, lush hedges and canopy trees line the deck and frame the perennial sunlight, setting the stage for breathtaking tableaux that would have enchanted Slim Aarons.

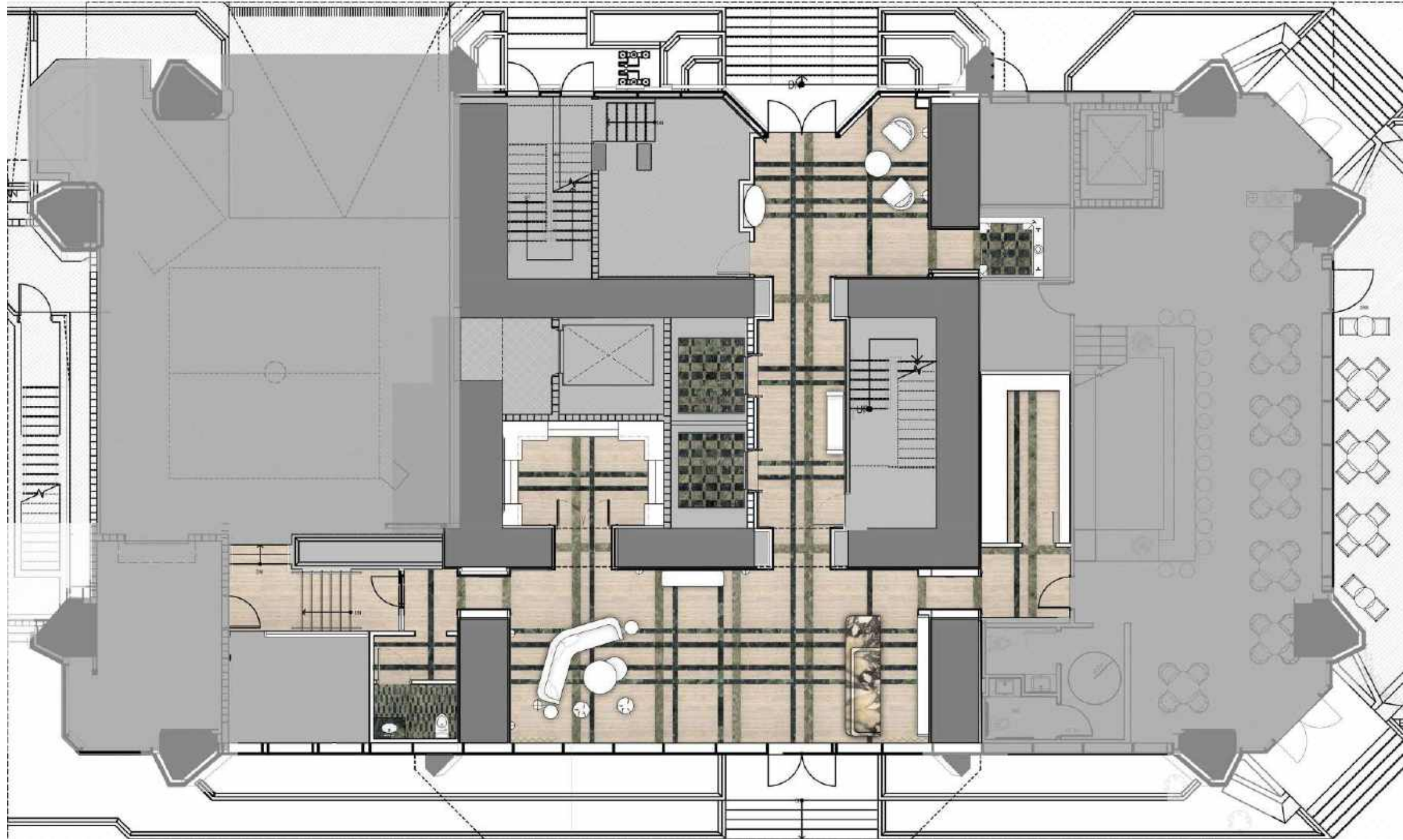

LEVEL 1

LOBBY & ENTRANCE

Villa Miami's grand entrance, designed to prioritize bayfront views, welcomes residents with lush materials and quiet sitting spaces.

GREEN ENVY

Custom marble floors, created from layers of Costa Esmeralda granite from Italy and Empress Green marble from China, line Villa Miami's elegant entrance.



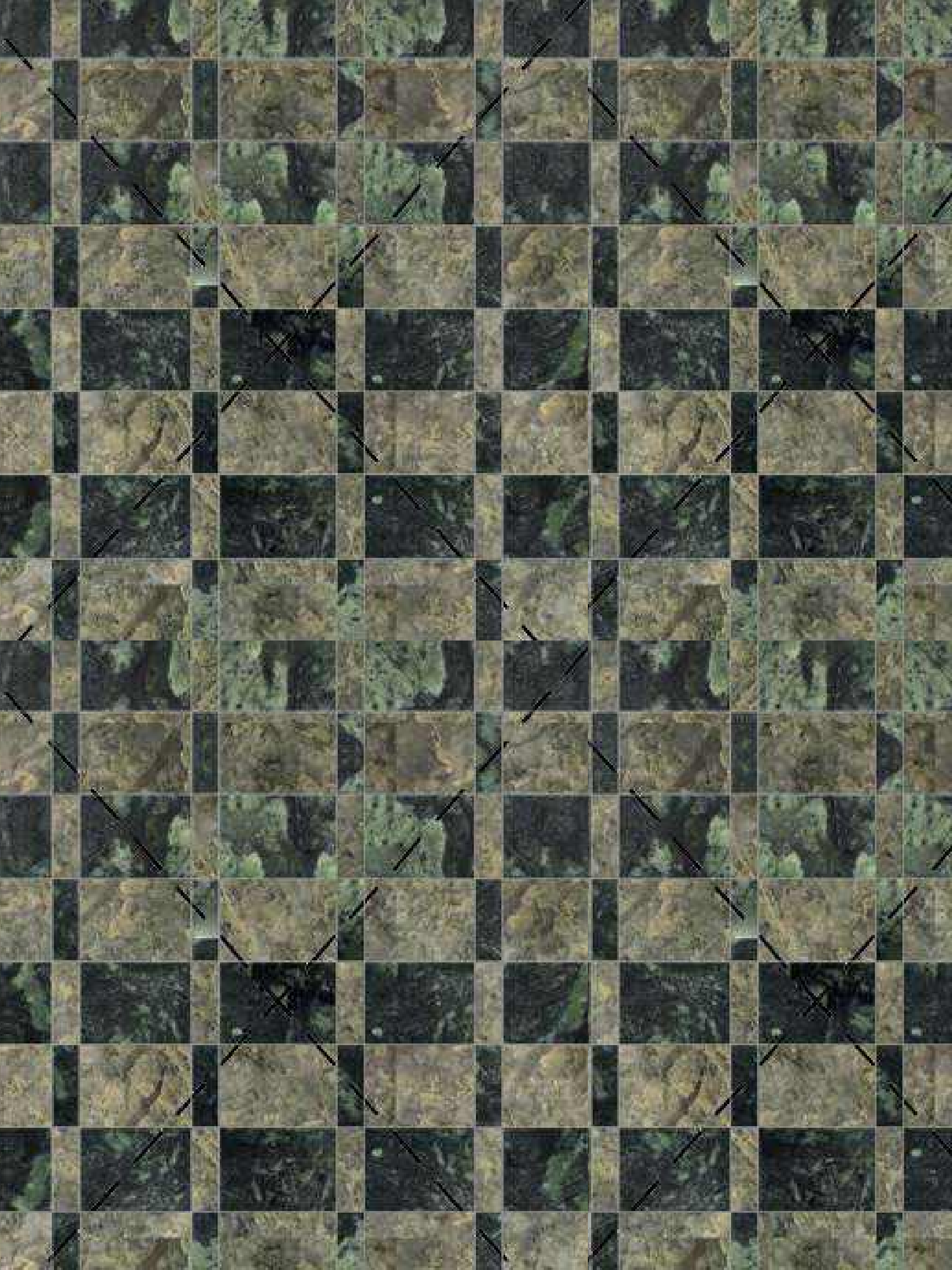

GOING UP

Here, elevators are extensions of the home, lined through the vestibule in custom granite and marble floors and topped by curved ceilings.

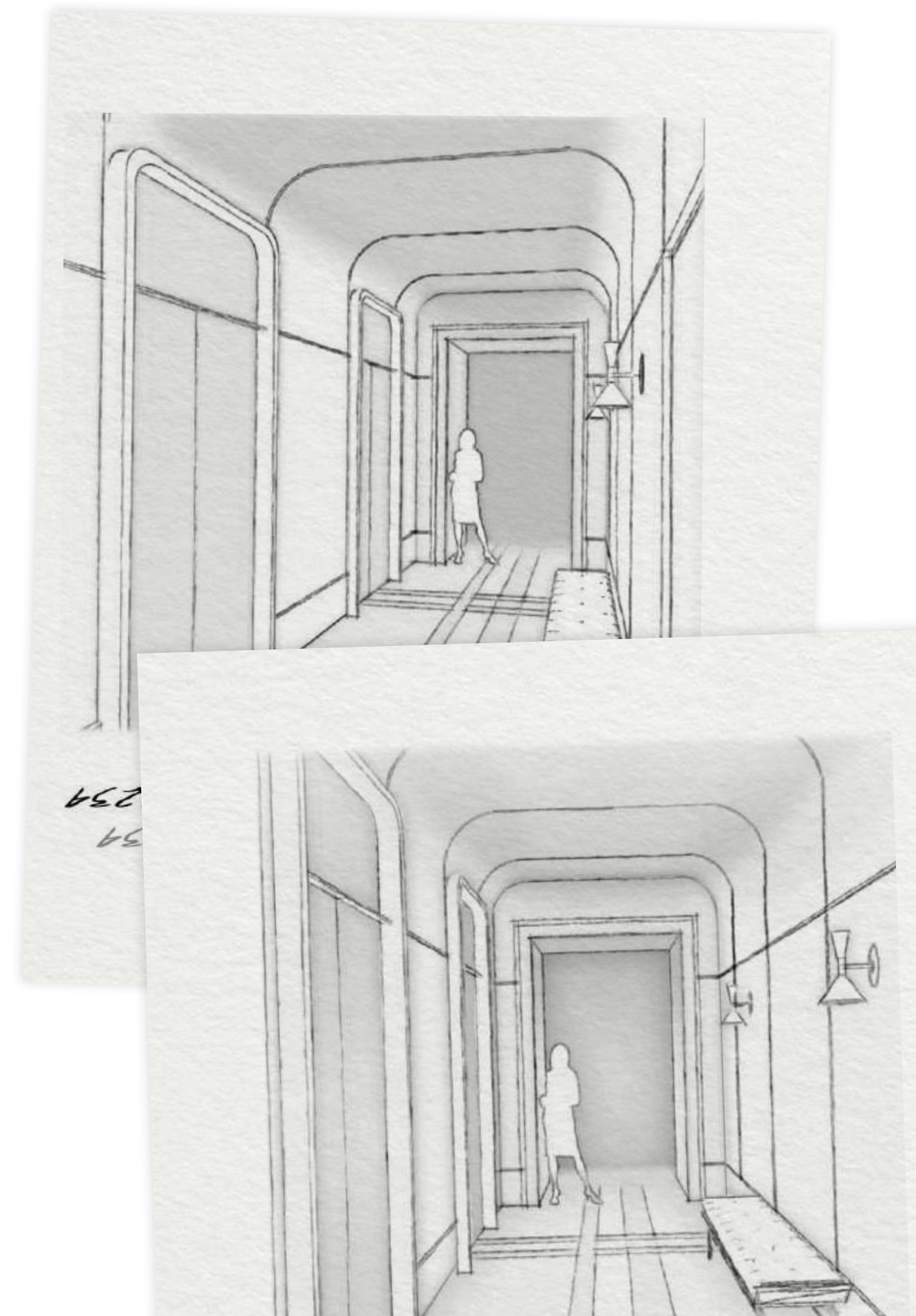



LEVEL 3
THE CLUB

Villa Miami's club beckons residents with a whole host of comfortable but eclectic modern spaces for quiet study, cozy conversation and private gatherings.

KEY

- | | |
|--------------------------------------|-------------------------------|
| 01 Small Private Dining & Conference | 06 Curator's Lounge |
| 02 Library Study | 07 Major Domo's Office |
| 03 Pantry | 08 Reception |
| 04 Great Room | 09 Management Conference Room |
| 05 Private Dining | |

A SUMPTUOUS PALETTE

In keeping with Villa Miami's Italian-inspired design approach, the stone, textiles and textures found throughout the club infuse the space with a rich warmth and timeless splendor.

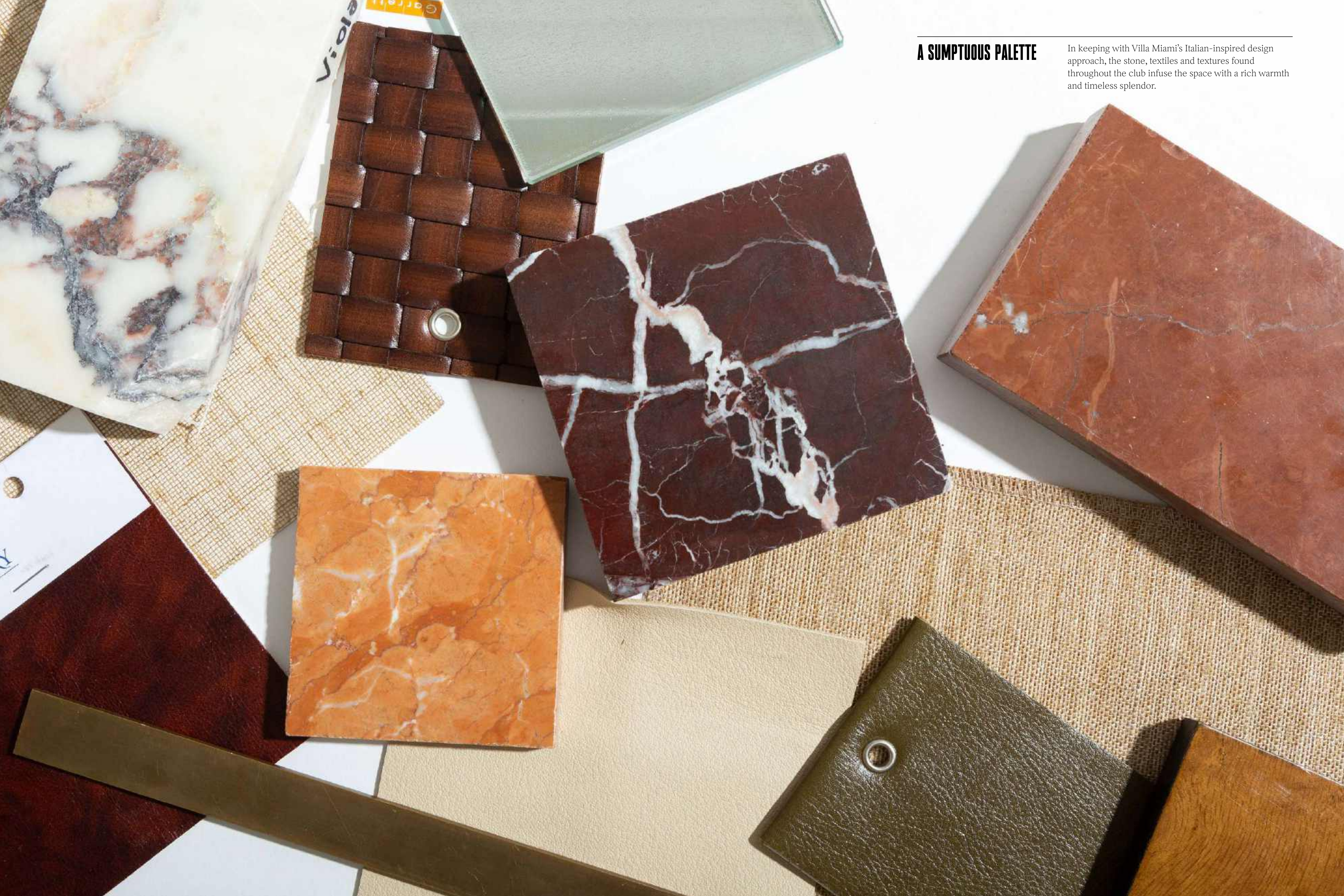

**A SPACE FOR
EVERY OCCASION**

Welcome to Villa Miami's club, a private lounge for morning meetings, afternoon drinks and festive evenings. The space is warm and welcoming, wrapped in rich fabrics and warm wooden surfaces.



West Elevation



East Elevation



South Elevation



North Elevation



South Elevation



West Elevation



East Elevation



STRAIGHT FROM THE CARRERA MOUNTAINTOP

The bar's backsplash and many other surfaces throughout Villa Miami are built from Carrera marble, a distinctive stone quarried in Tuscany's Carrara for more than 2,000 years and was beloved by many Roman and Renaissance sculptors, including Michelangelo.





Private residents lounge



Private dining room

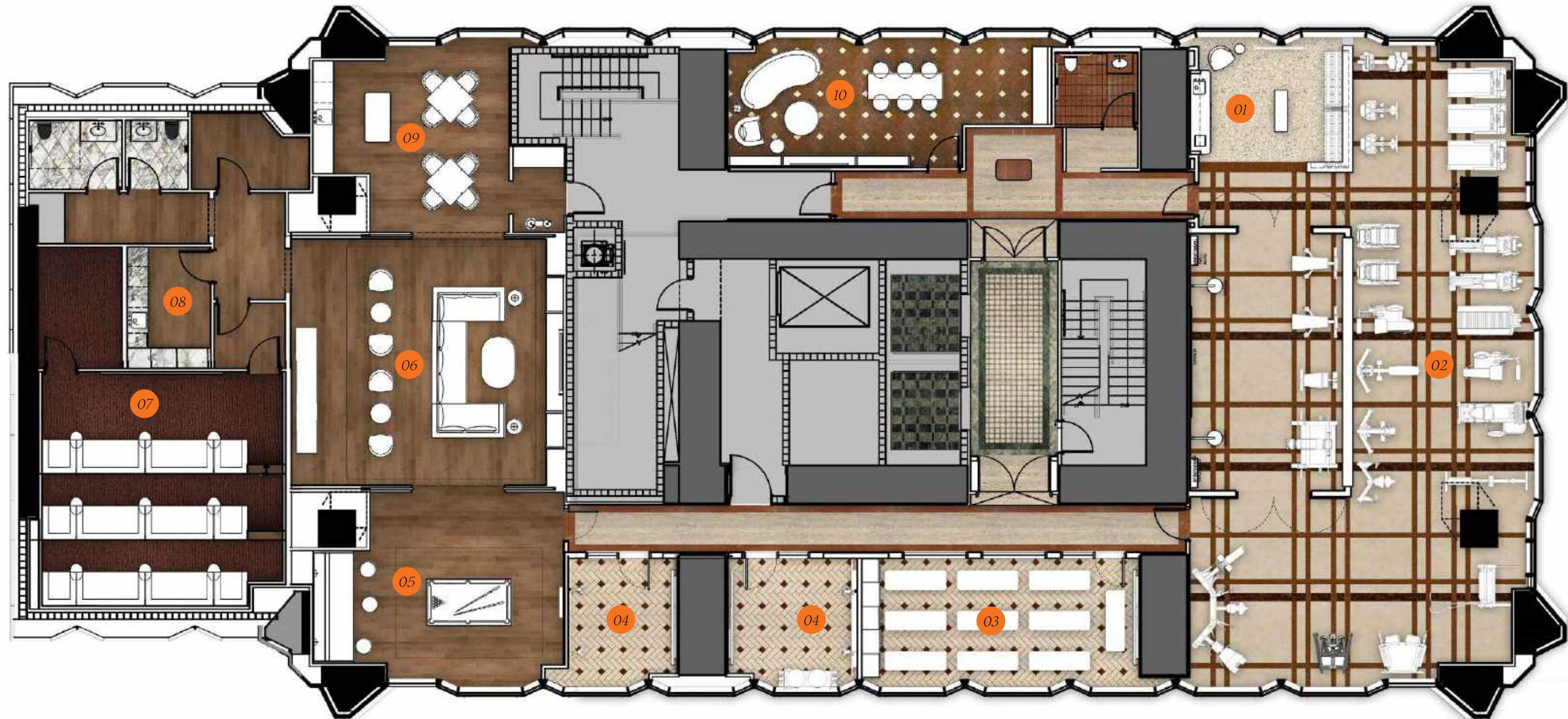

LEVEL 4
THE CLUB

The private residents' spaces continue on the fourth floor, where our luxurious state-of-the-art gym and cozy cinema screening room are found.

KEY

- | | |
|--|--------------------------|
| 01 <i>Stretching Zone</i> | 06 <i>Club Room</i> |
| 02 <i>Fitness Studio</i> | 07 <i>Screening Room</i> |
| 03 <i>Group Fitness & Yoga Room</i> | 08 <i>Pantry</i> |
| 04 <i>Personal Fitness & Boxing Room</i> | 09 <i>Poker Lounge</i> |
| 05 <i>Billiard Room</i> | 10 <i>Family Lounge</i> |



Residents' club room with library and intimate lounges



Residents' club room with library and intimate lounges

STUNNING STONES

One of Villa Miami's most distinctive features is its custom stone floors, including this soft green Costa Esmeralda granite from Italy, beloved for its signature light green and gold veining.



A WELL EQUIPPED WORKOUT SPACE

The Villa Miami gym, lined with beautiful views of the bay, is fully stocked with state-of-the-art Technogym machines and equipment and built with dedicated spaces for yoga and private training.



West Elevation



West Elevation



East Elevation



North Elevation

East Elevation

West Elevation







**MOVIE NIGHTS
WITH STYLE**

The private screening room is cloaked in wonderfully plush materials and optimized with wooden acoustic panels for high-quality sound, perfect for streaming everything from classic standbys to the latest releases.





Screening Room

A LOUNGE FOR THE YOUNGEST RESIDENTS

In the family lounge, chalk walls offer a creative canvas for infinite possibilities while floral wallpapers and cozy chairs encourage even the littlest guests to play.

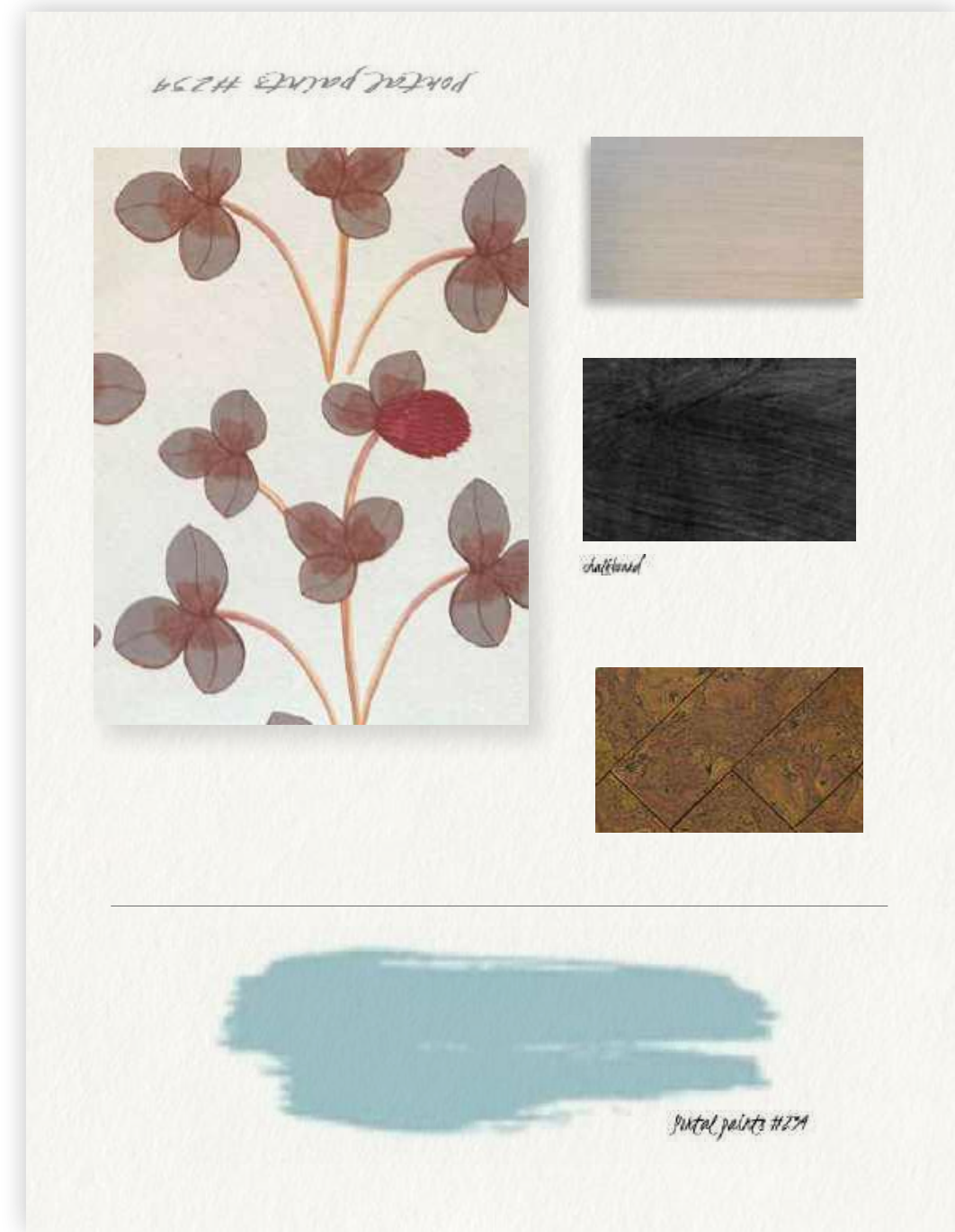



Dedicated kids' lounge

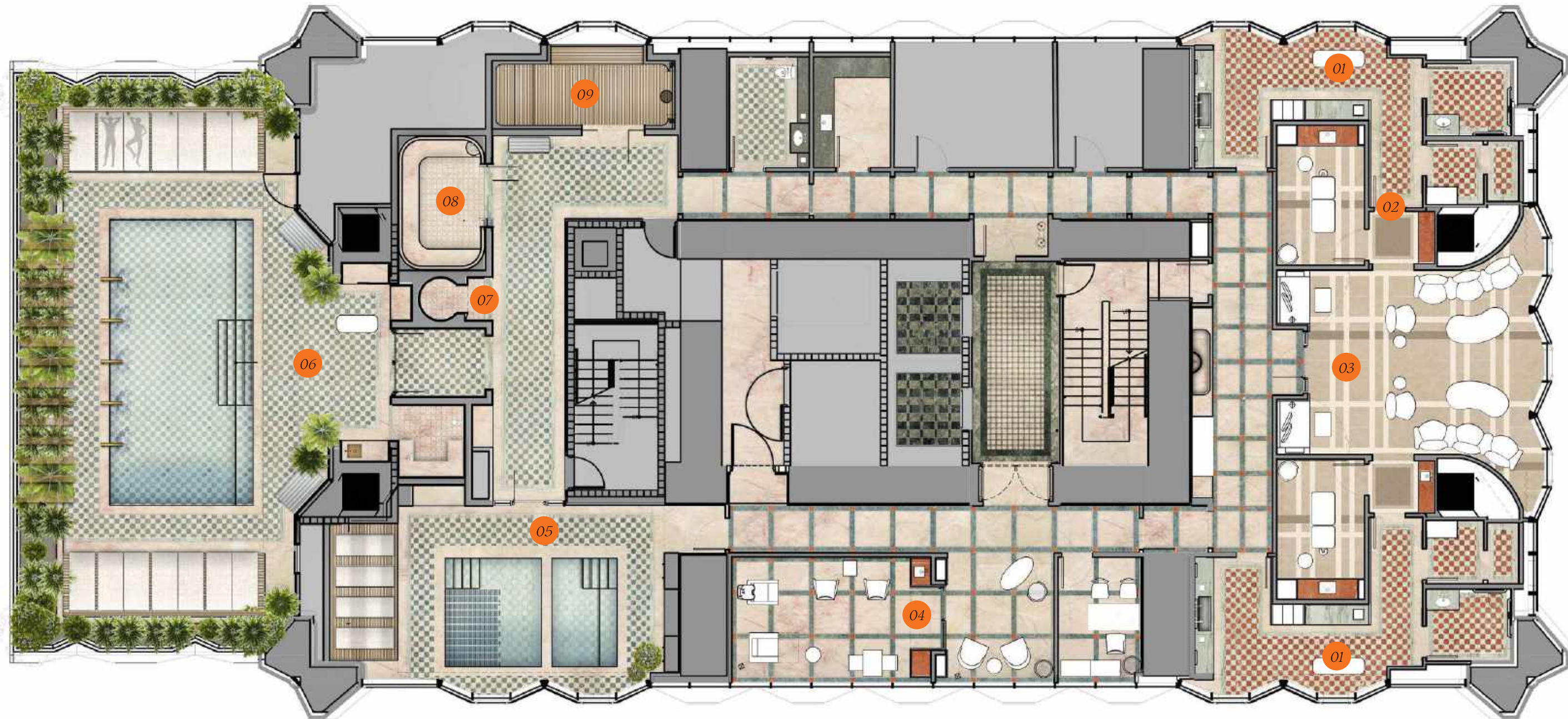

LEVEL 5
POOL & SPA
EXPERIENCE

Welcome to Villa Miami's wellness destination, where you'll find our ultra-luxury spa, fully equipped sauna, hot and cold plunge pools and much more.

KEY

- | | |
|----------------------|---------------------------------|
| 01 Locker Rooms | 06 Outdoor Pool & Deck |
| 02 Spa | 07 Sensory Chromotherapy Shower |
| 03 Relaxation Room | 08 Herbal Steam Shower |
| 04 Salon | 09 Sauna |
| 05 Hot & Cold Plunge | |



AQUATIC PALETTE

Rich but serene materials including Navona Alabastrino travertine, New Castle quartzite and Zellige tiles lend the pool deck and spa rooms a deep tranquility.

TIME FOR A DIP

Villa Miami's serene outdoor pool, lined in geometric stone pattern that extends across the deck, is cocooned by soft green granite, an abundance of leafy plants and the Miami sunshine.



East Elevation

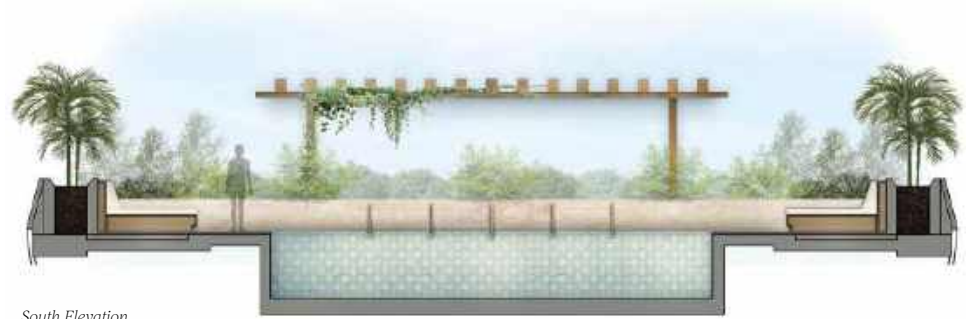

South Elevation

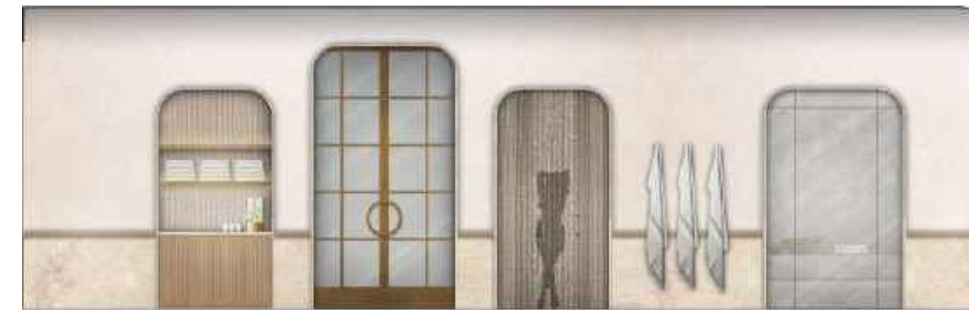

West Elevation





Outdoor pooldeck with lounges and daybeds



*Outdoor pooldeck with
lounges and daybeds*



Plunge pools



Steam room



PEACEFUL PATTERNS

Pops of orange Rosso Verona marble, imported from Italy, dot the distinctive custom flooring in the spa, where soft blue and beige stone sets a stage for calm and stillness.

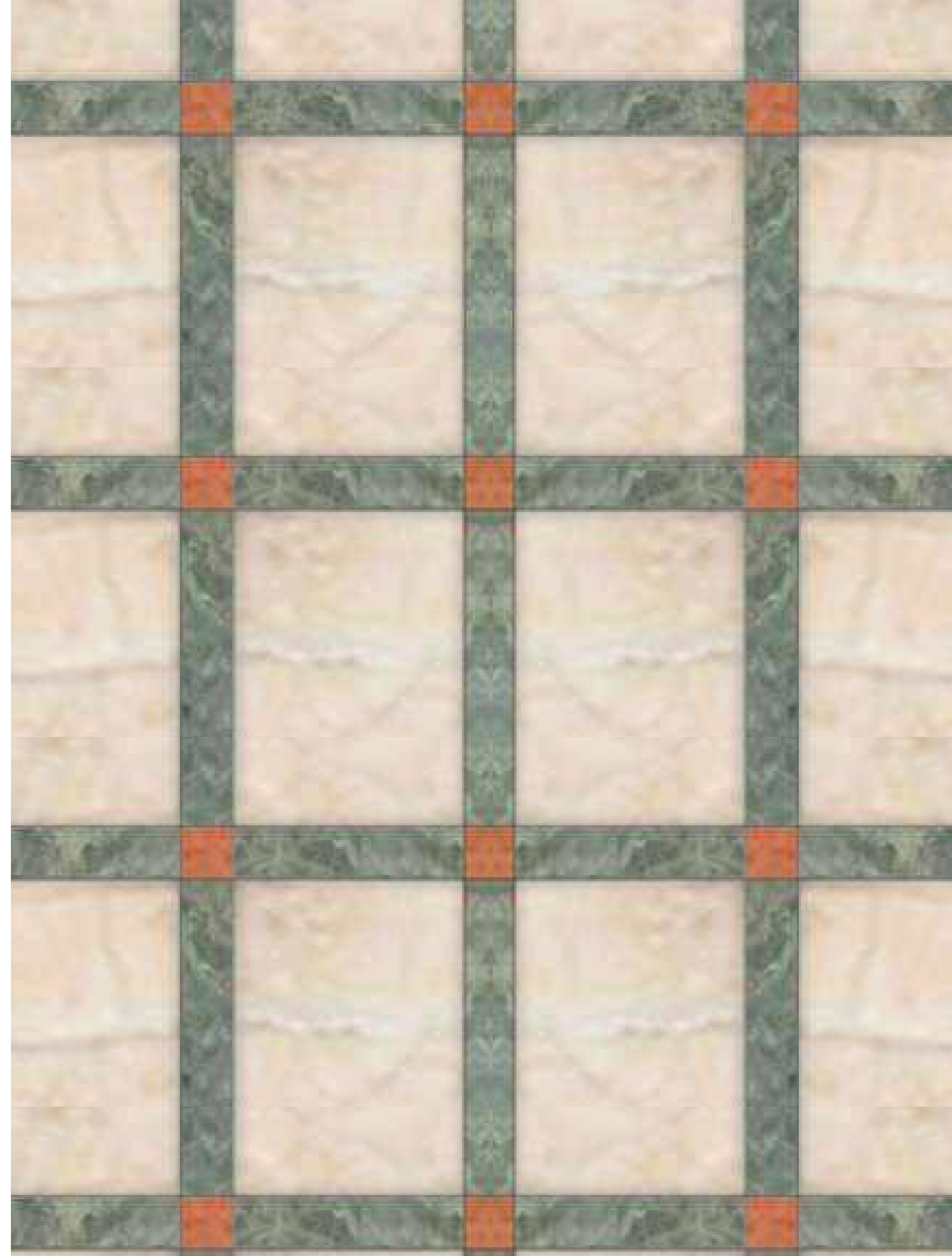



04

RESIDENCE DESIGN

**OLD-WORLD ELEGANCE WITH EVERY
MODERN CONVENIENCE**

152

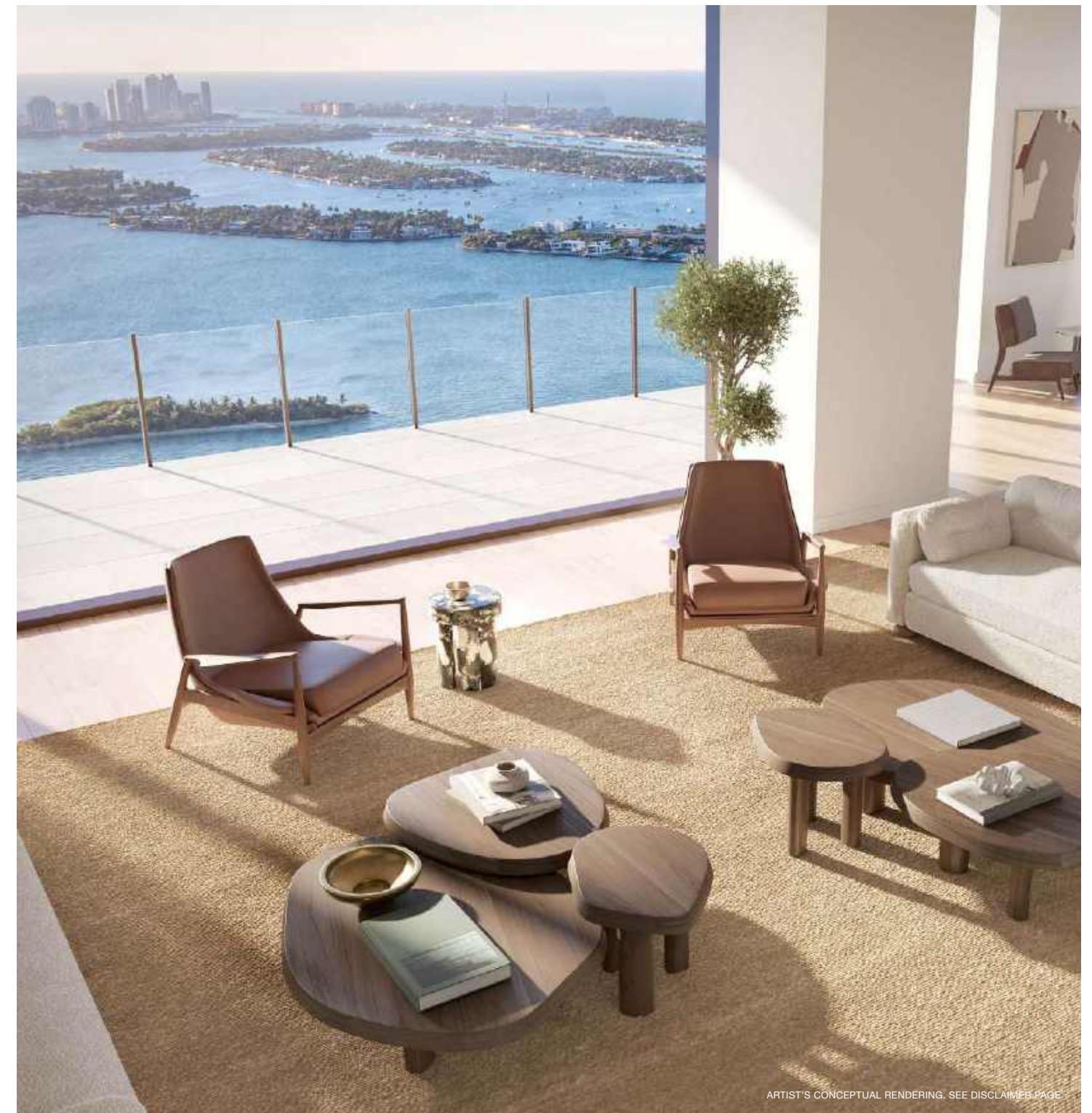

Sunlight at every waking hour. That's the lifestyle that awaits inside Villa Miami, where the panoramic views, fresh air and constant sunshine bring every home a distinctive warmth.

Every residence is designed for easy customization but is filled with the kind of opulent details and ingenious design that define the Villa Miami experience.

Here, sprawling living rooms encourage unforgettable gatherings, while dining rooms are perfect for hosting dinners and late-night feasts. Of course, the kitchen is the heart of the home, where your family unwinds and where you perfect your agnolotti. Residences come equipped with chef-worthy kitchens designed by Major Food Group's own Mario Carbone, featuring pasta tanks and convection steam ovens.

Living rooms blend into Villa Miami's epic views of the bay and beach beyond.

153

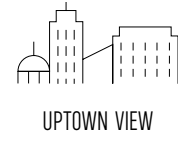

UPTOWN VIEW

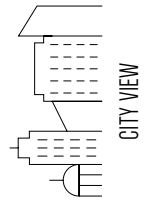

CITY VIEW



LEVELS 6-52

360-DEGREE-VIEW RESIDENCES

Every Villa Miami home covers a full floor, a design advantage rarely found in Miami and in high-rise living.

From the quartz countertops to the wood flooring and crisp off-white walls, each residence is rendered in warm but versatile materials that allow residents to bring their own style to their most intimate spaces.



“

**WE WERE DRAWN TO
WARM, ELEGANT
MATERIALS TO CREATE
AN ATMOSPHERE
OF EMBRACE. A HOME
SHOULD FEEL WELCOMING
AND NURTURING**

VICKY CHARLES

”



Spacious sunrise and sunset terraces



Dining room



Living room



Great room

**DESIGNED TO
MAXIMIZE VIEWS**

Given Villa Miami's unique proximity to the bay, ODP's architects prioritized maximizing views, ensuring every floor comes with its breathtaking perspectives of Miami's skyline and waterways.

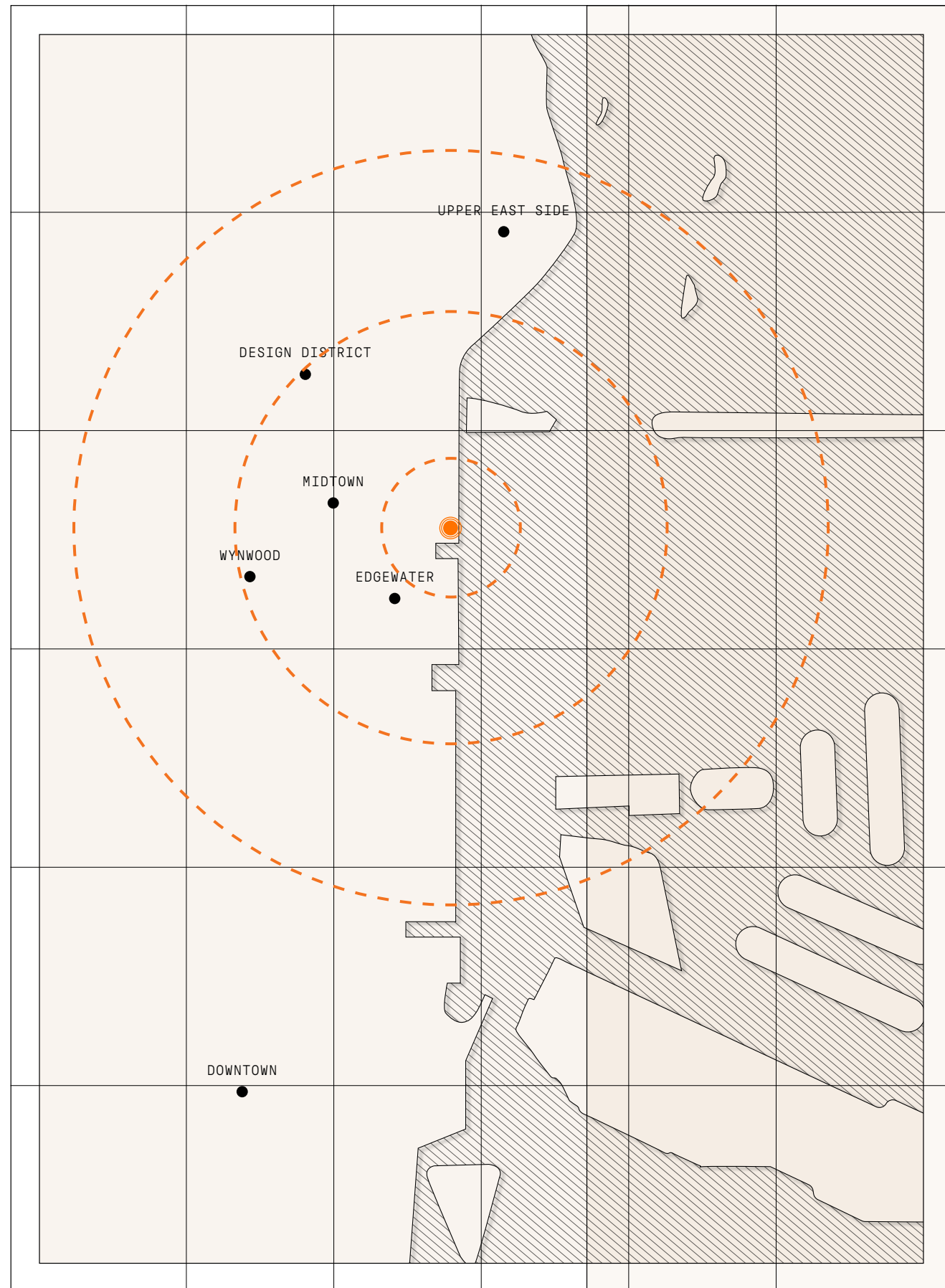

“

**EDGEWATER IS BECOMING
THIS INCREDIBLE
NUCLEUS OF THE NEW
MIAMI - AND VILLA
MIAMI IS AT THE CENTER
OF IT ALL.**

ONE THOUSAND GROUP

”

**MIAMI FROM
EVERY ANGLE**

From sunrise to sunset and every moment in between, Villa Miami never fails to deliver epic views, especially of Miami's famous beaches, waterways and skylines.







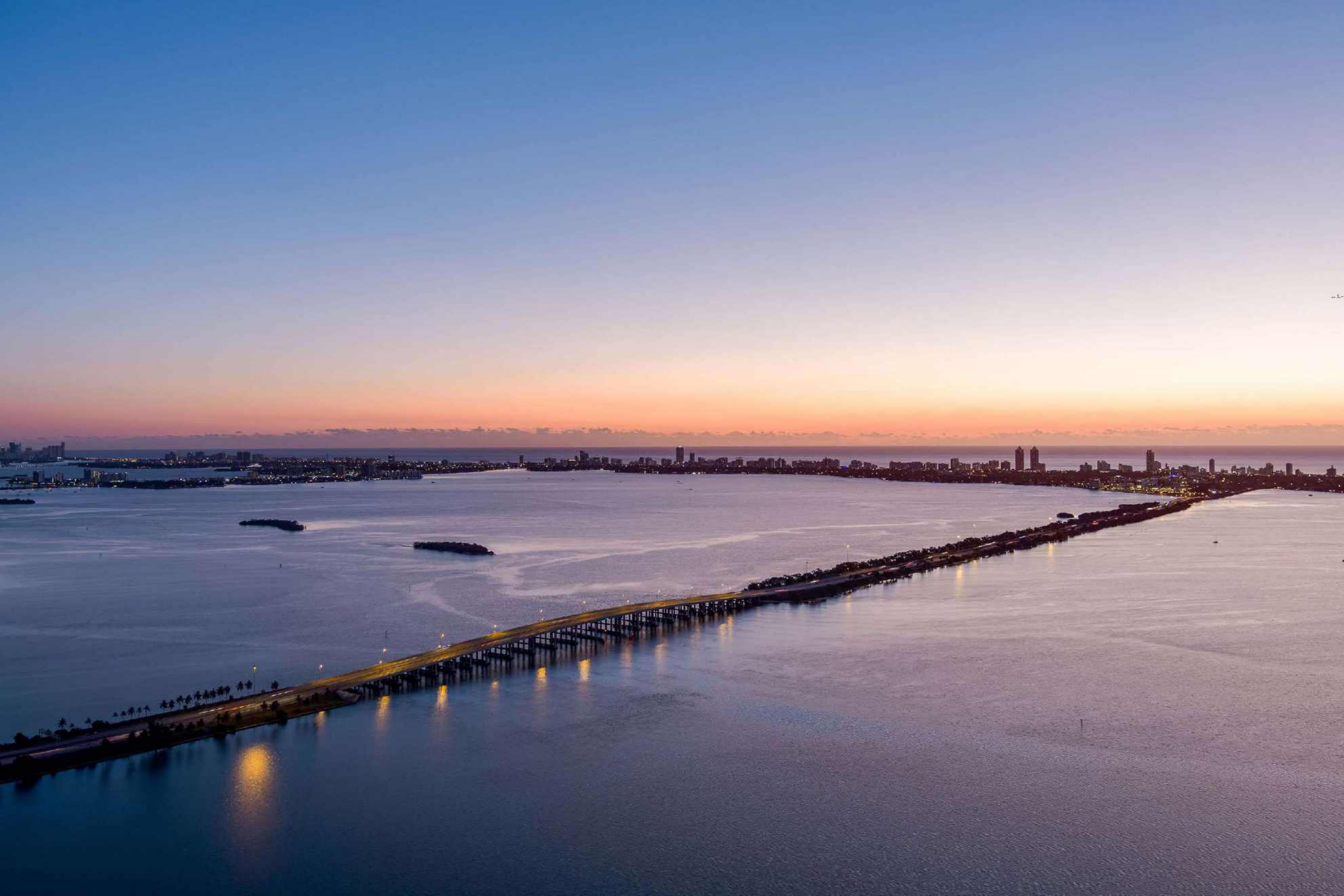





**HOME KITCHENS
FIT FOR GENFS**

Handcrafted French La Cornue ranges offer unrivaled craft and efficiency for roast, sear and broil.

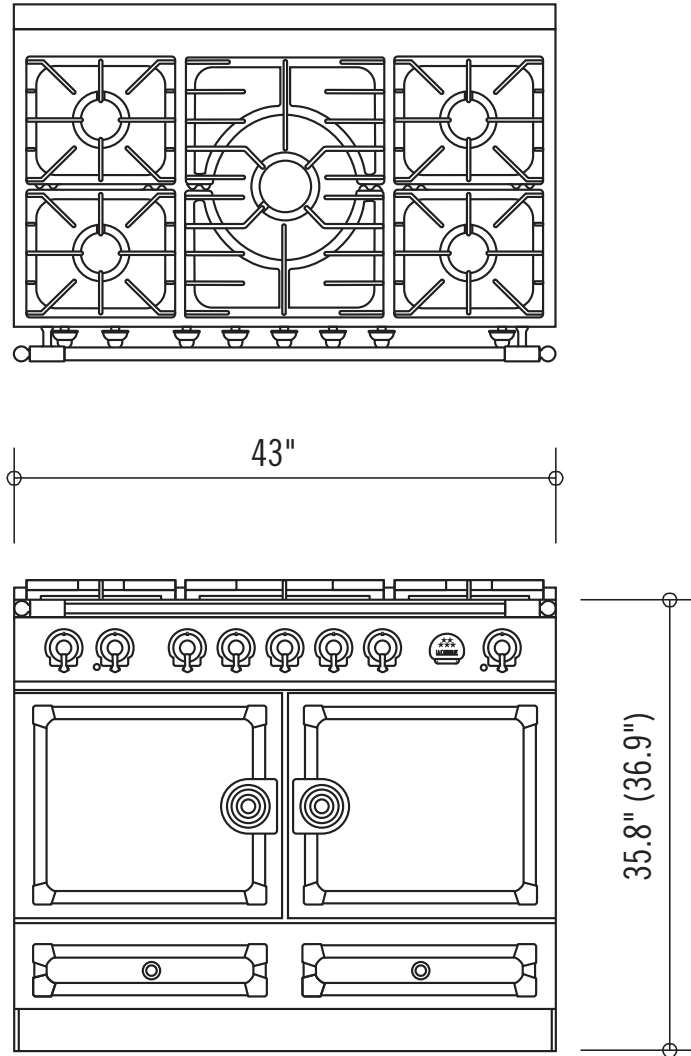

**PERFECT PASTA,
EVERY TIME**

Overseen by MFG's master chef Mario Carbone, Villa Miami's kitchens come equipped with brass pot filler faucets and pasta cookers for a perfect al dente every spaghetti night.





*Chef's kitchen designed
by Mario Carbone*

ARTIST'S CONCEPTUAL RENDERING. SEE DISCLAIMER PAGE



*Chef's kitchen designed
by Mario Carbone*

ARTIST'S CONCEPTUAL RENDERING. SEE DISCLAIMER PAGE.



*Chef's kitchen designed
by Mario Carbone*

ARTIST'S CONCEPTUAL RENDERING. SEE DISCLAIMER PAGE.

LUXURY AT HOME

Greige Onyx, intricately patterned in warm, soft tones, plays a central role in Villa Miami's bathrooms, where curved and translucent surfaces prioritize light without sacrificing privacy.

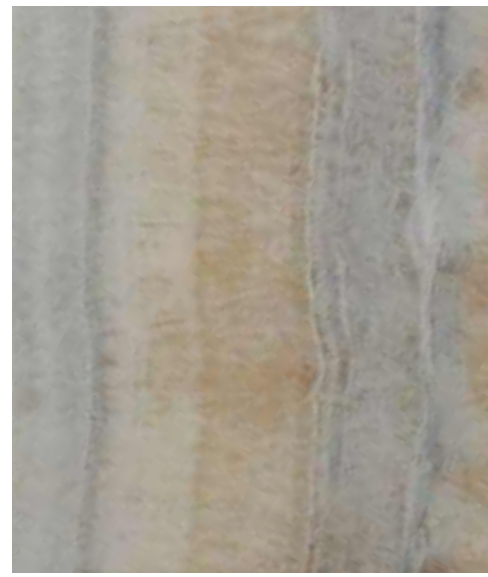

TOP BRASS

Brushed durabronz fixtures, refined with 23-carat gold, complement the bathroom's soft opulence and rich materials.



192



193





Primary en-suite bathroom



Primary bedroom suite

ARTIST'S CONCEPTUAL RENDERING. SEE DISCLAIMER PAGE.



Primary bedroom suite

05

TOWER & GROUNDS

**FROM SUNRISE TO SUNSET,
A LIFE DESIGNED AROUND THE HORIZON**

200



ARTIST'S CONCEPTUAL RENDERING. SEE DISCLAIMER PAGE.

A gemstone rises, sparkling, from the edge of the bay, as striking when seen from miles away as it is when viewed from the waterfront below. This is Villa Miami's most prominent contribution to its city, an instant landmark whose geometric facade was inspired by the way light bounces off water, designed to resemble the refractive edges of a gemstone through its "bubbles" of glass. Angled glass facades undulate in and out, offering a geometric expression of ripples in the water and cut with a precision designed to recall the surface of a diamond. The distinct copper exoskeleton encases the towering diamond, a reminder that this building is as innovative as it is daring.

For the team at ODP Architects, Villa Miami's 360° views represented privilege and a priority. Every entry point, whether to the residences or the grand lobby, is positioned to feature a straight view of the water, the lights of Miami or the far-stretching beaches beyond. Similarly, the building's landscape design prioritizes the breathtaking bayfront. Verdant textures define Villa Miami's grand entrance, flanked by large, diverse canopy trees that offer shade and character and frame a view of the water as soon as residents turn off Biscayne Boulevard. At the base of the building, landscape architect Enzo Enea created a series of private gardens, filled with native flowering trees and designed to offer moments of contemplation.

Villa Miami's distinctive copper exoskeleton glows at sunset.

201



Private dock with boat slip

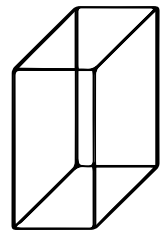

+

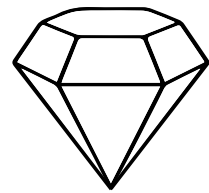

+

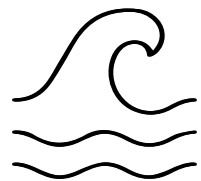

“

**A DESIGN
CONSTANTLY
ACCENTUATING
AND REFLECTING
LIGHT AS THE
SUN TRAVERSES
ITS EDGES.**

ODP ARCHITECTS

”

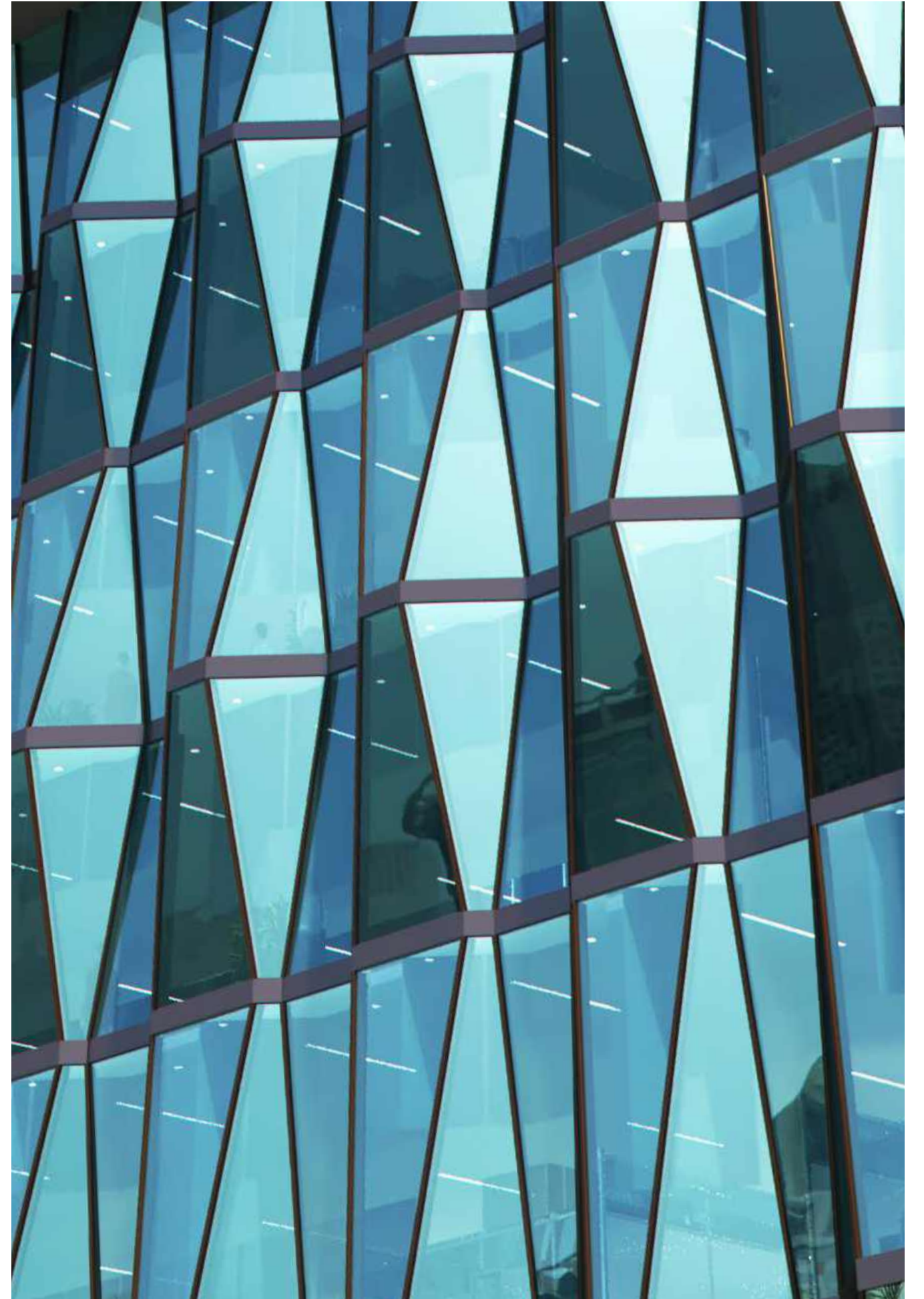

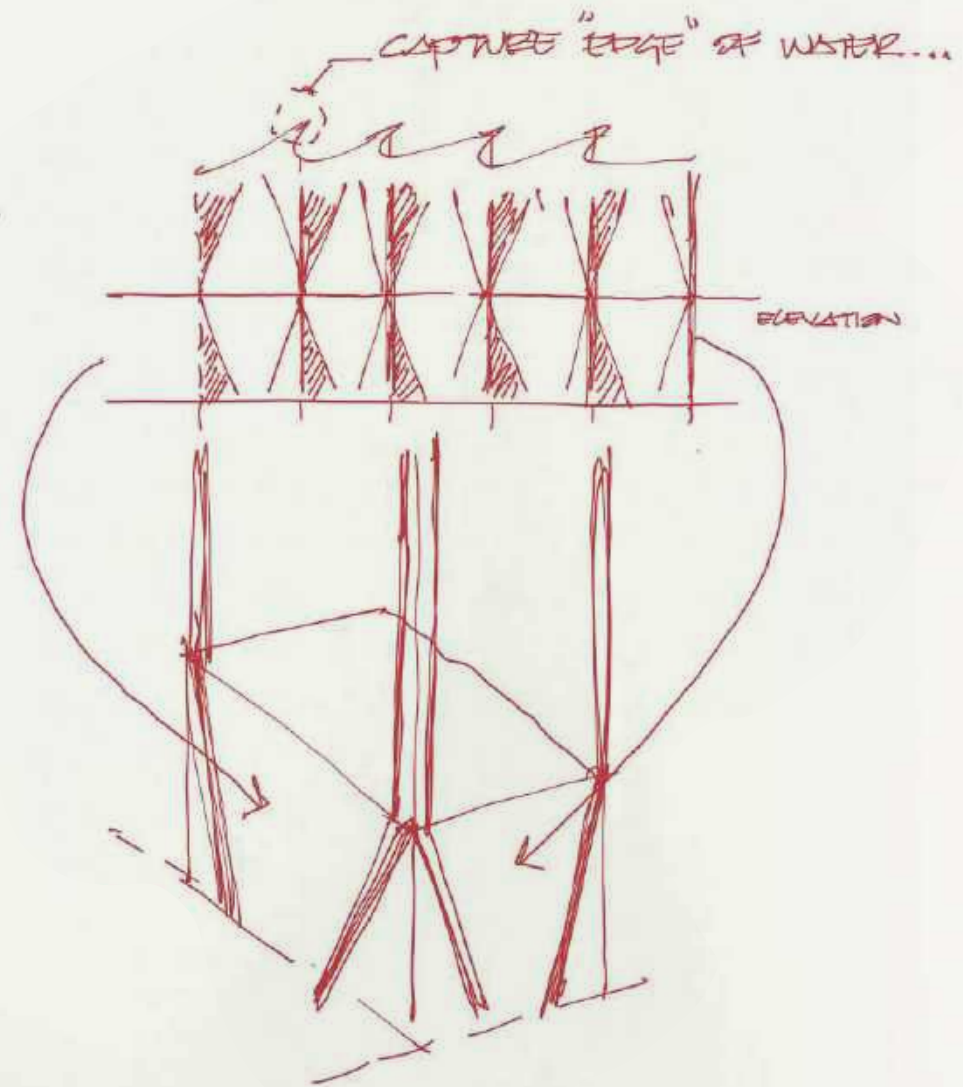

PLAN GEOMETRIC
FACADE IN "PRONG" STRUCTURE...

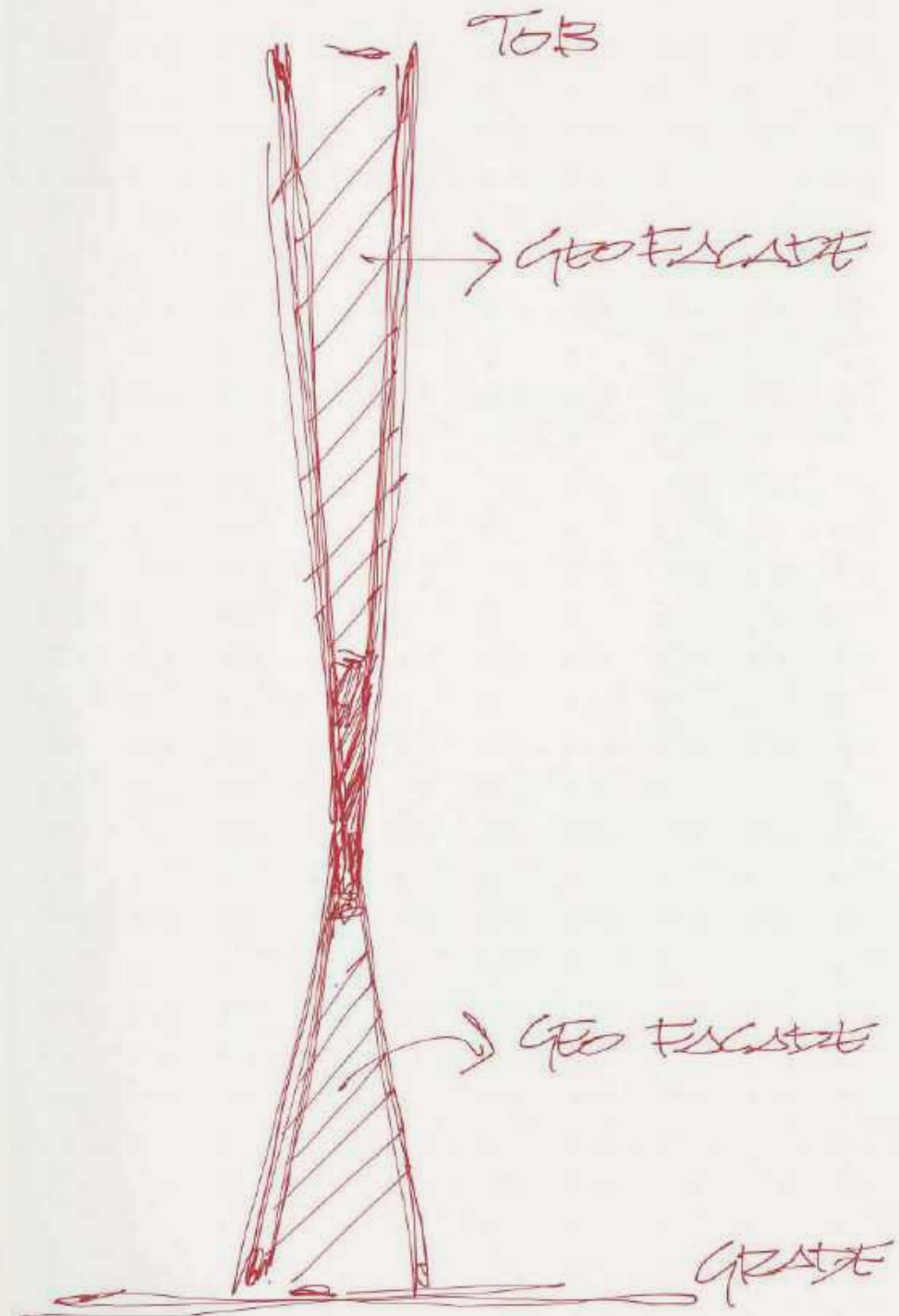

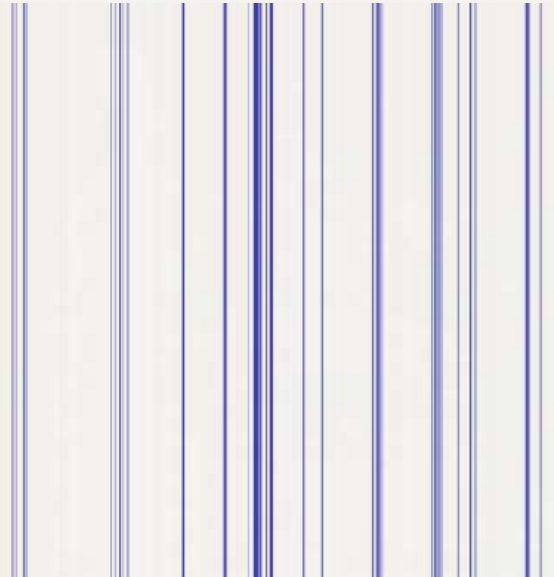
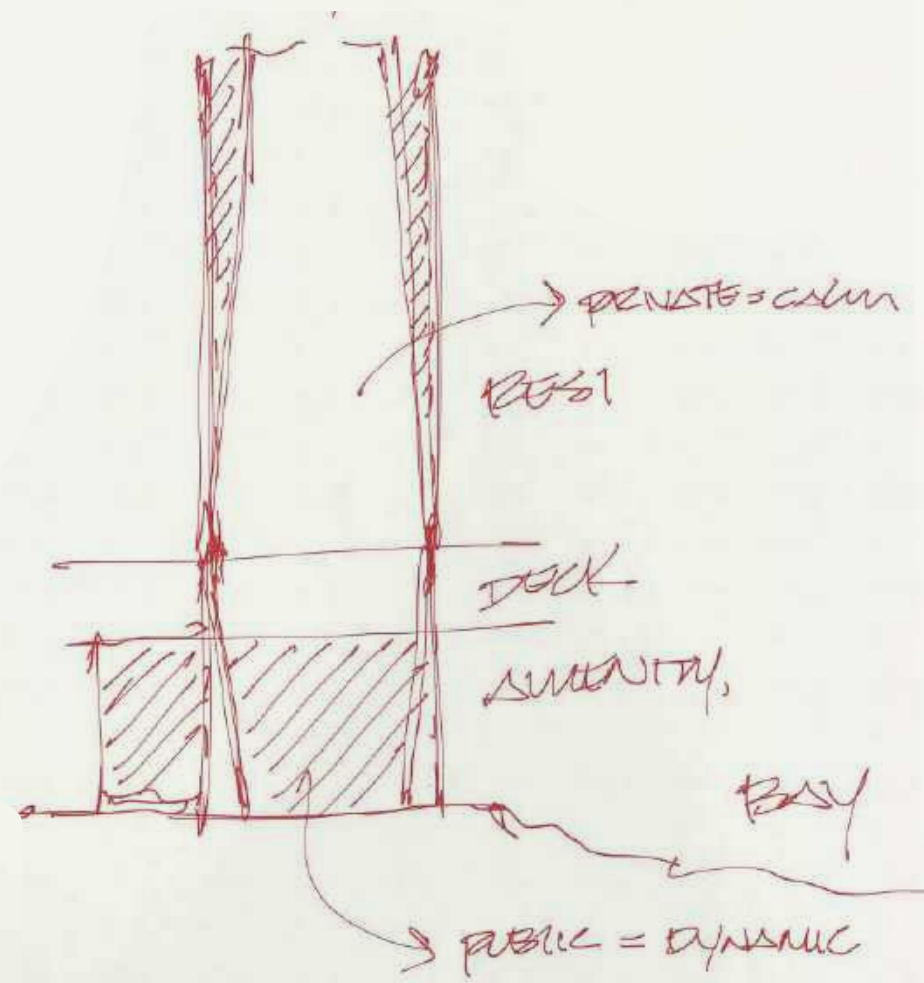

EXOSKELETON PROFILES

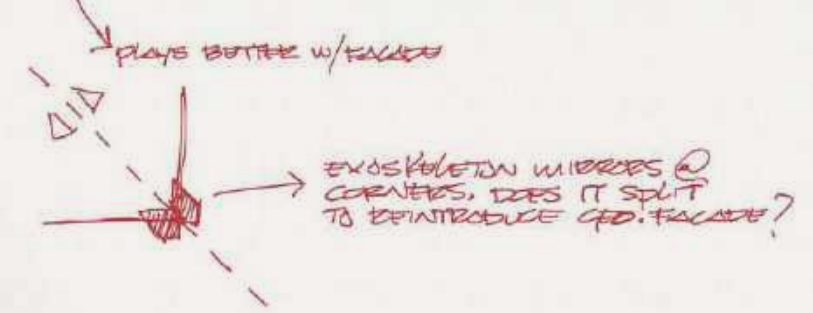
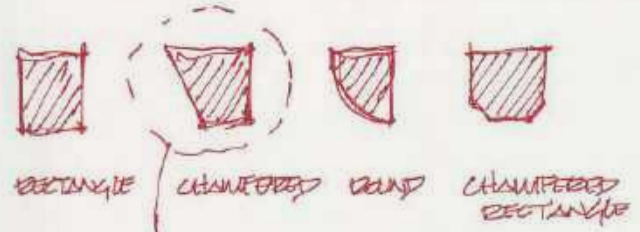

GIVING FORM TO VISION

The design process required multiple stages and scaled models to ensure the unique exterior was built in the ideal proportions.

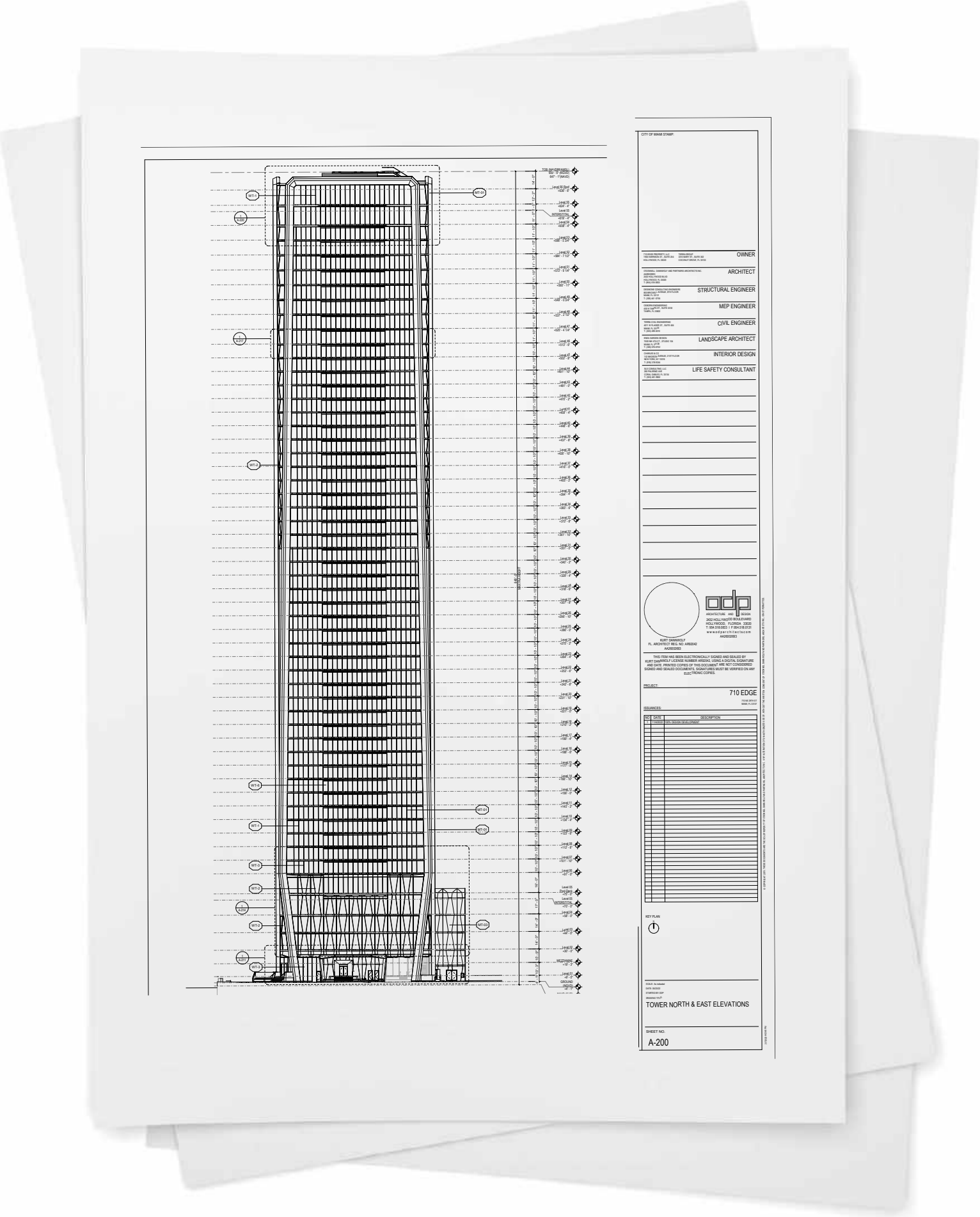

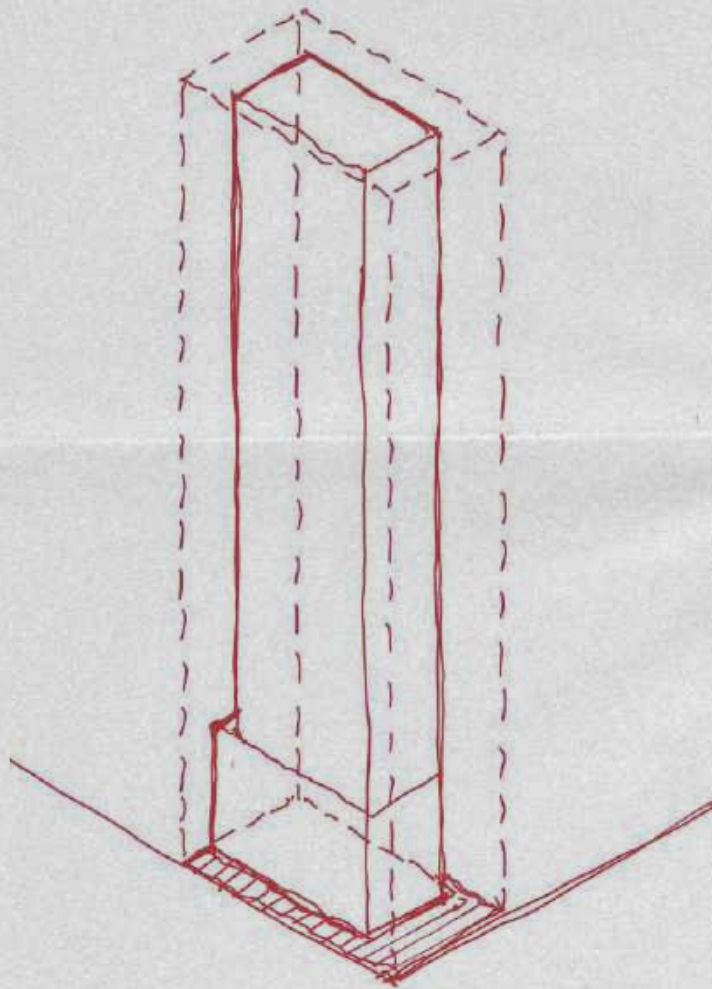

Bay

FULL VOLUME w/ SETBACKS

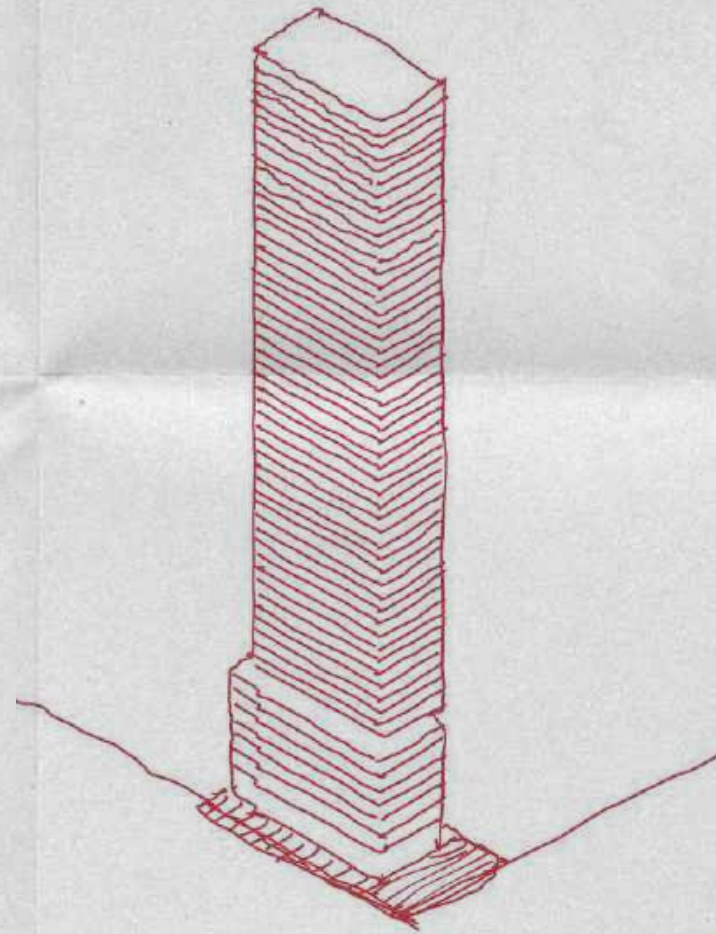

Bay

REPETITIVE FLOORS

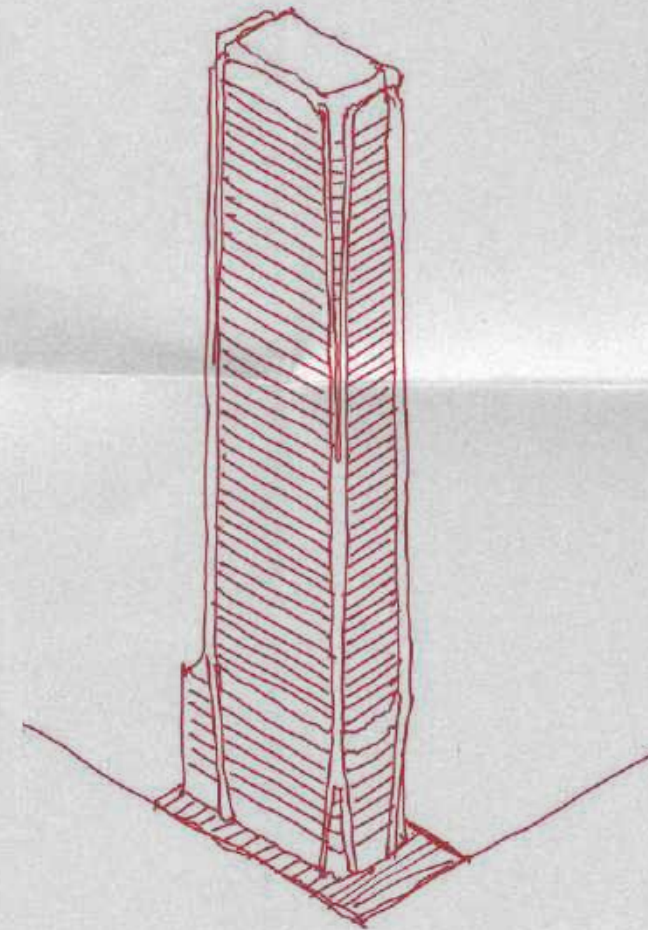

Bay

PRIMARY FRAME

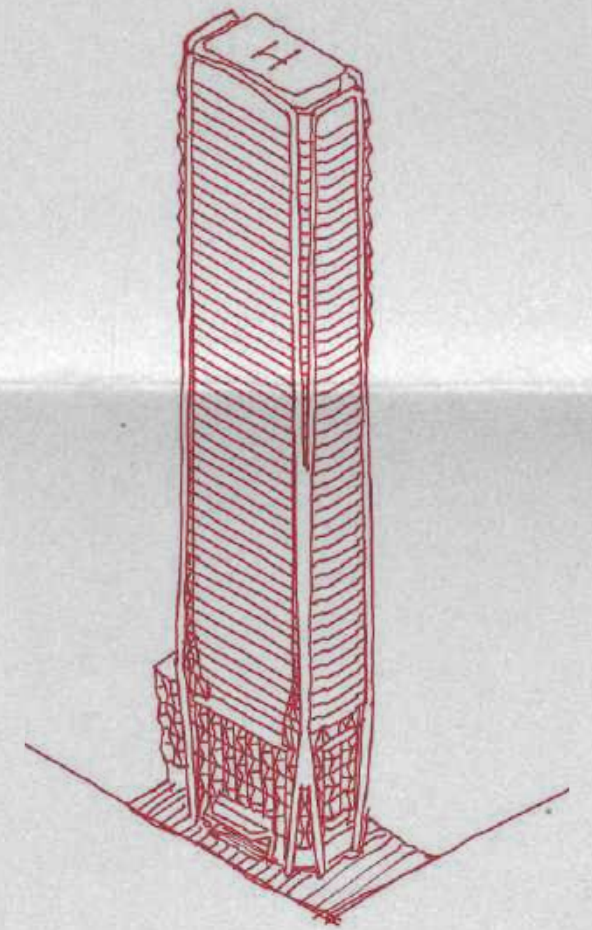

Bay

FACADE APPLICATION

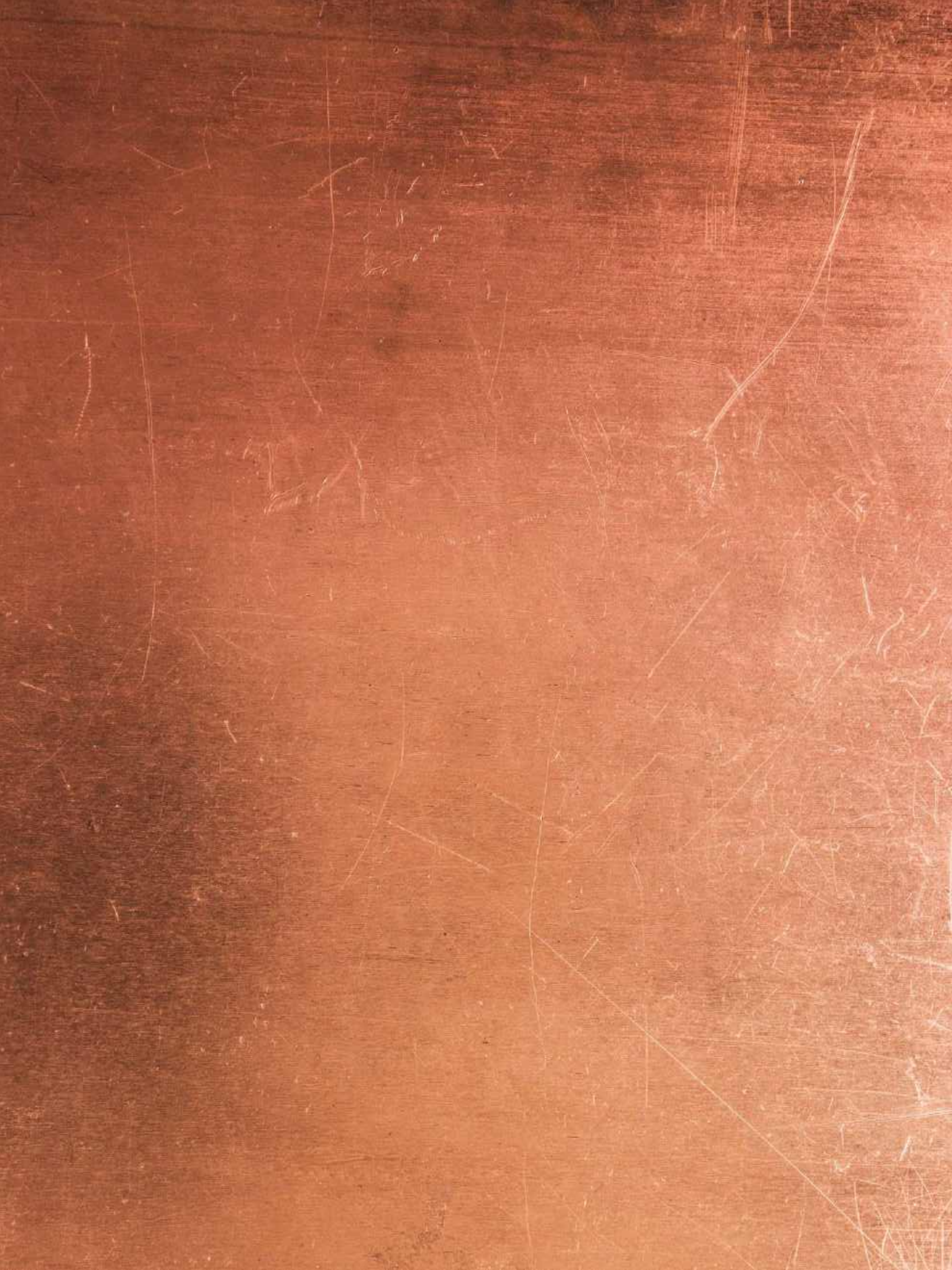

AN ALLURING PATINA

Villa Miami's copper-glazed exoskeleton, a modern idea rendered in traditional materials, is one of its most distinctive features and a departure from Miami's typical design conventions.



GIVING FUNCTION TO FORM

The architects considered several depths and widths for Villa Miami's unique facade to best frame the building's epic waterfront views.

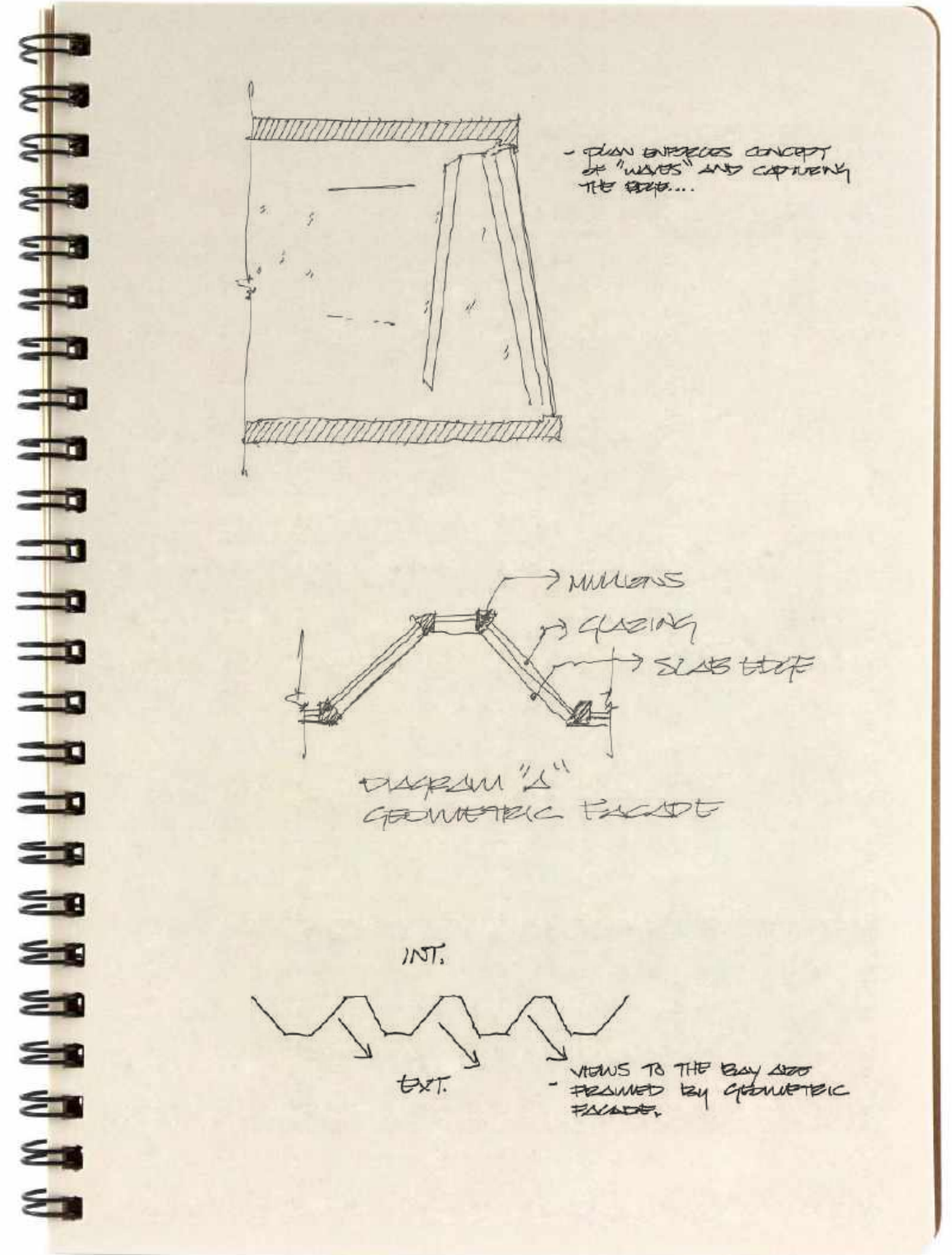
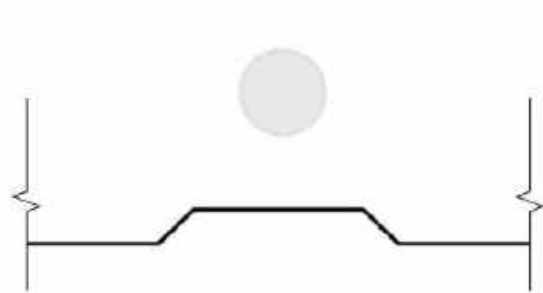
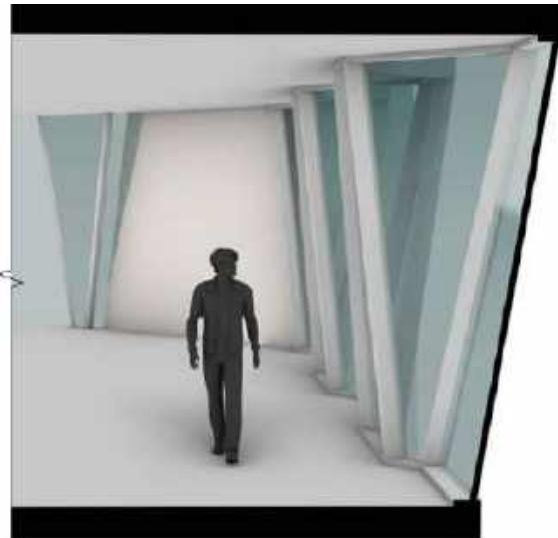



Porte-cochere drop-off

THE GROUNDS

Villa Miami emerges from a vibrant, verdant garden that surrounds the tower and anchors it in a wild and thriving natural world.

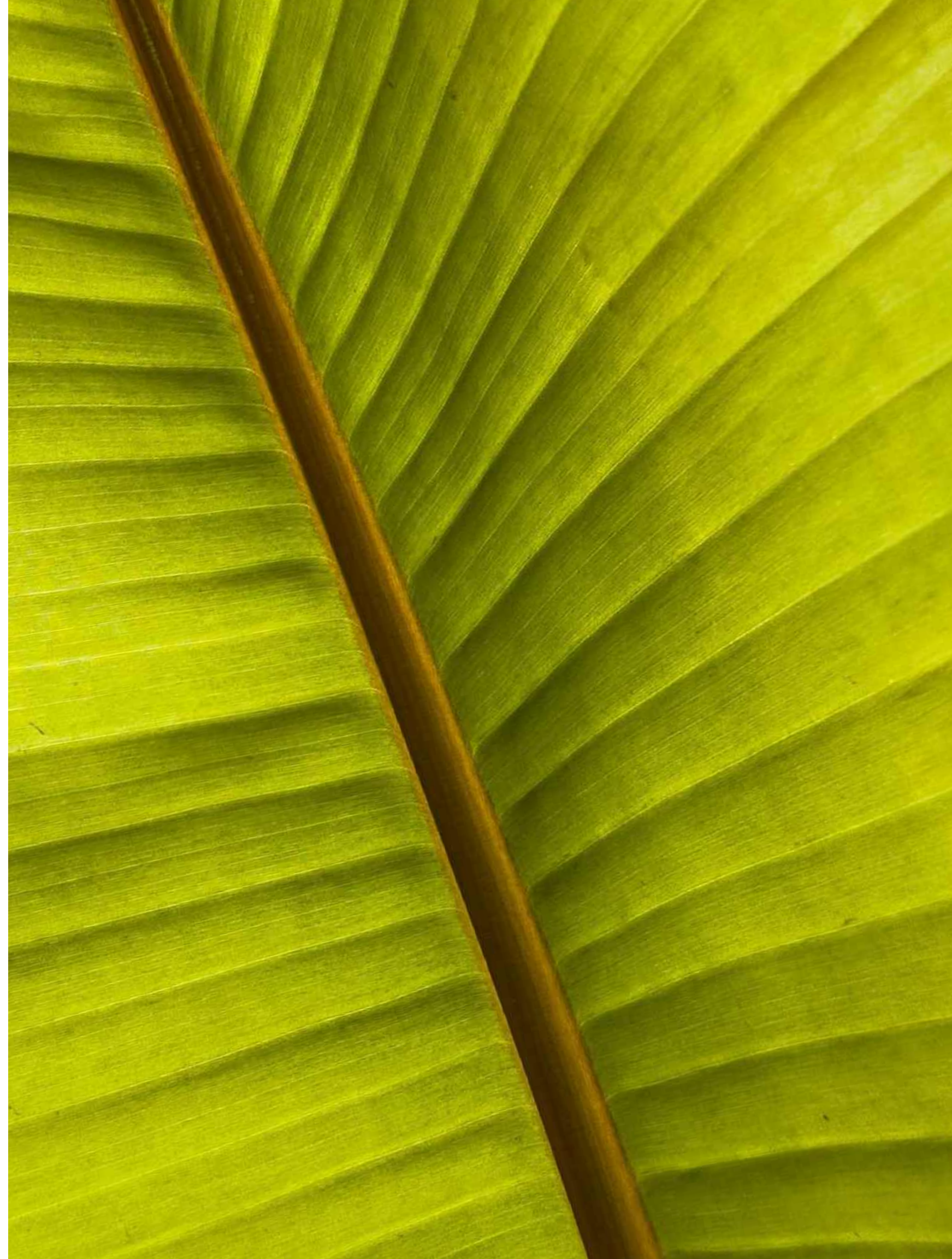

CREATING AN ELEGANT ENTRANCE

More than two dozen canopy trees line the entire length of 29th Street east of Biscayne Boulevard, transforming the drive into a tunnel of greenery.

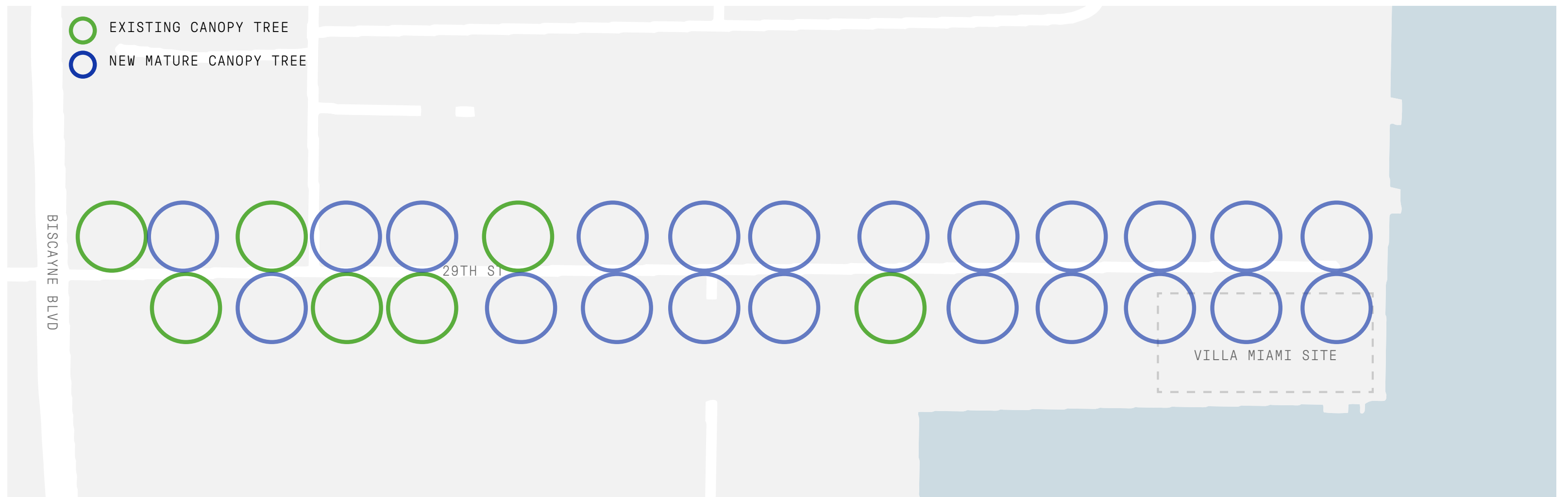

Villa Miami's gardens vary in texture and size, framing the tower with a lush landscape from every angle.

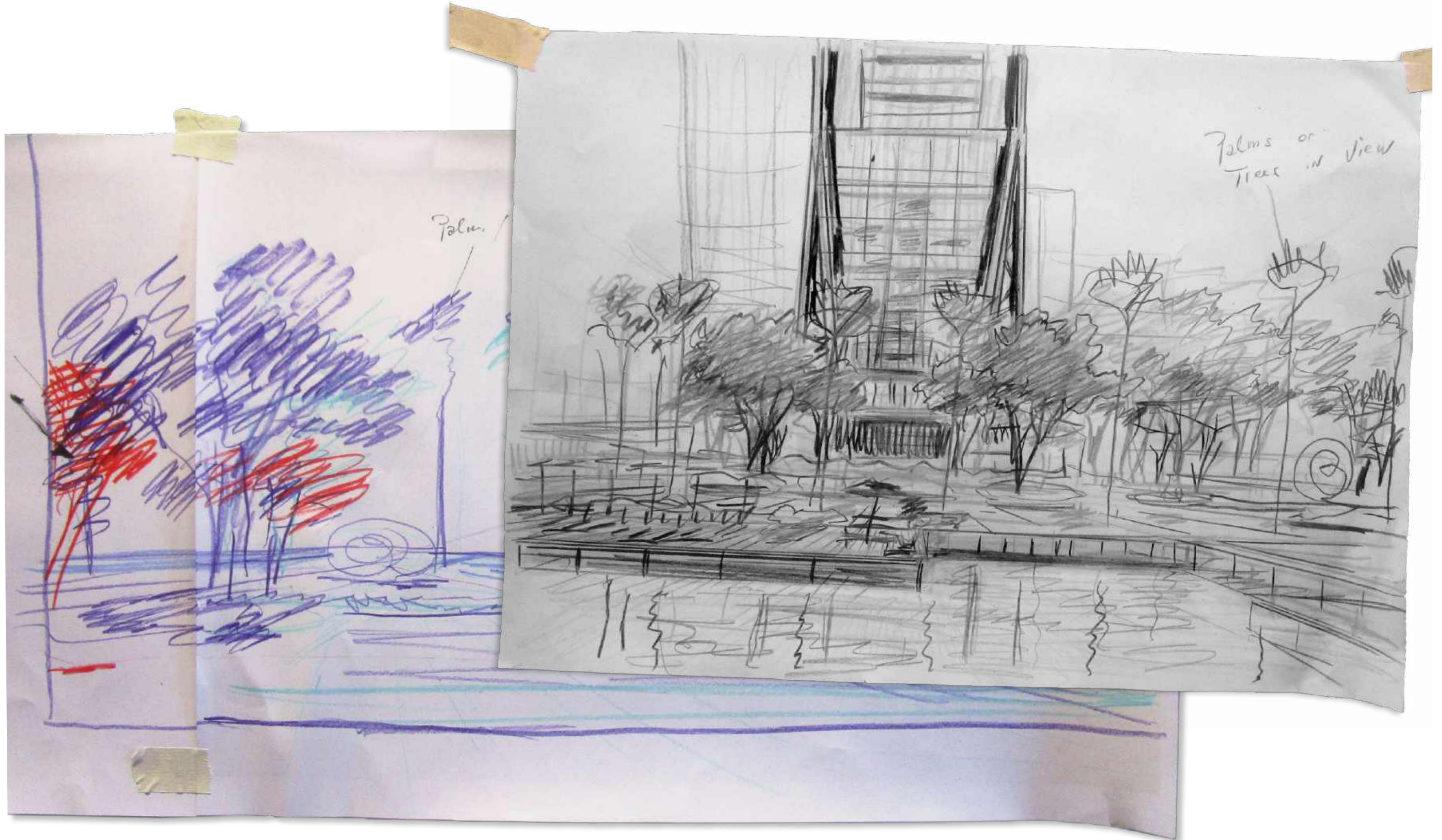

HARMONY IN VARIETY

With an expansive variety of flora, Villa Miami's gardens are designed to mature and bloom year-round, ensuring a constant evolution only possible in southern Florida.



Seagrape trees and Spider Lilies feature are just two of the native Florida plants featured prominently in Villa Miami's diverse gardens.

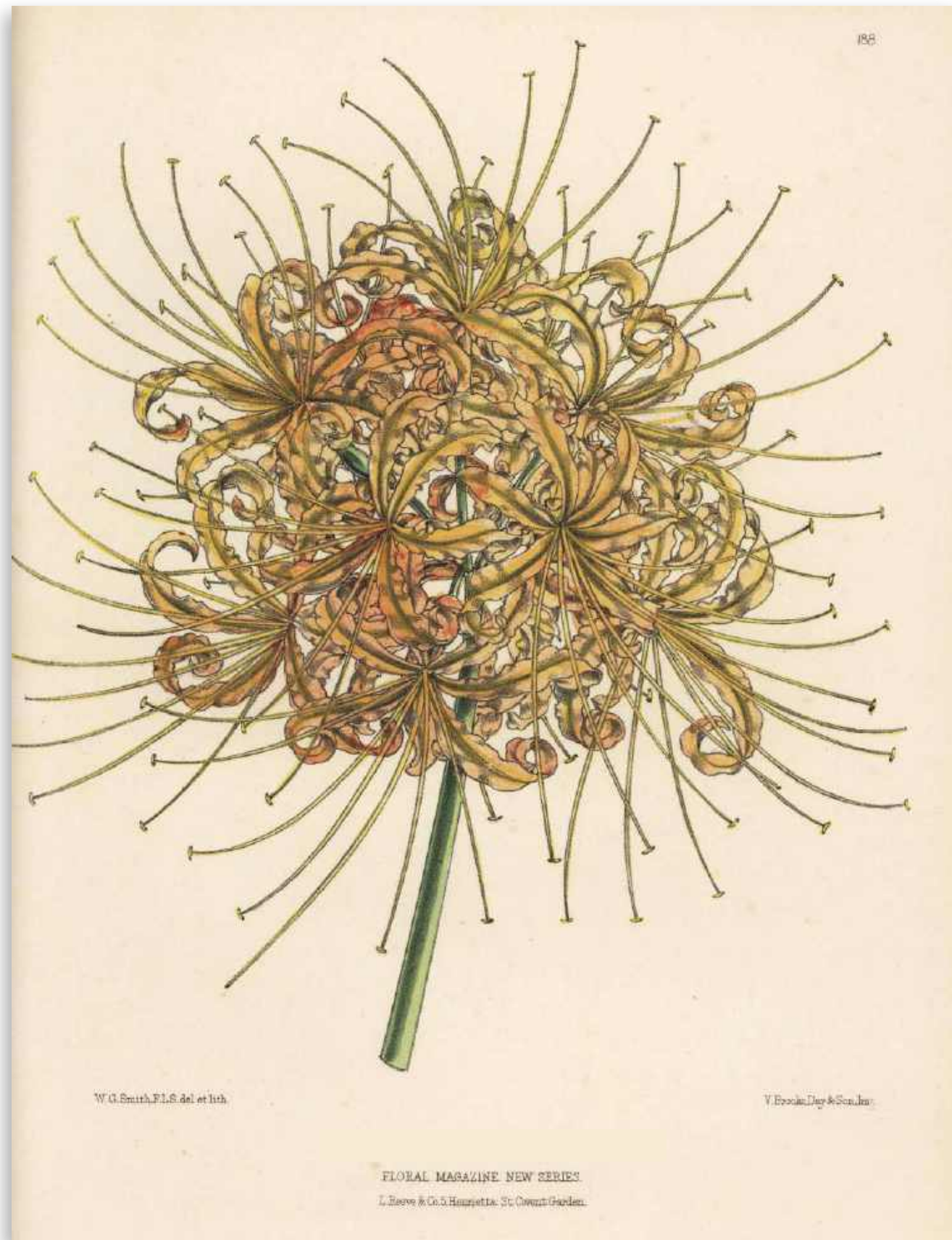

LEAFY LAYERS

Villa Miami's landscape designers at Enea curated the gardens to create depth and textures through varied heights and widths of the featured greenery.

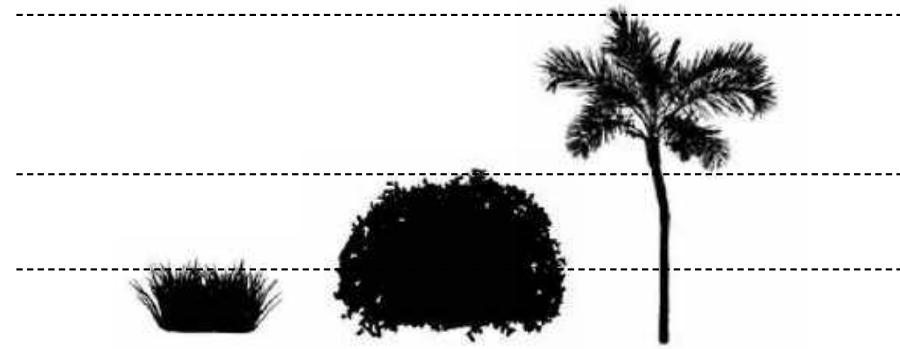

- TALL/BUFFER
- GRASSES
- LOW/FLORING

CREATING DEPTH AND LAYERS

From the cobblestones to the ridges of the tree bark, textures play a key role in the dialogue between Villa Miami's garden, streetscape and structural design.

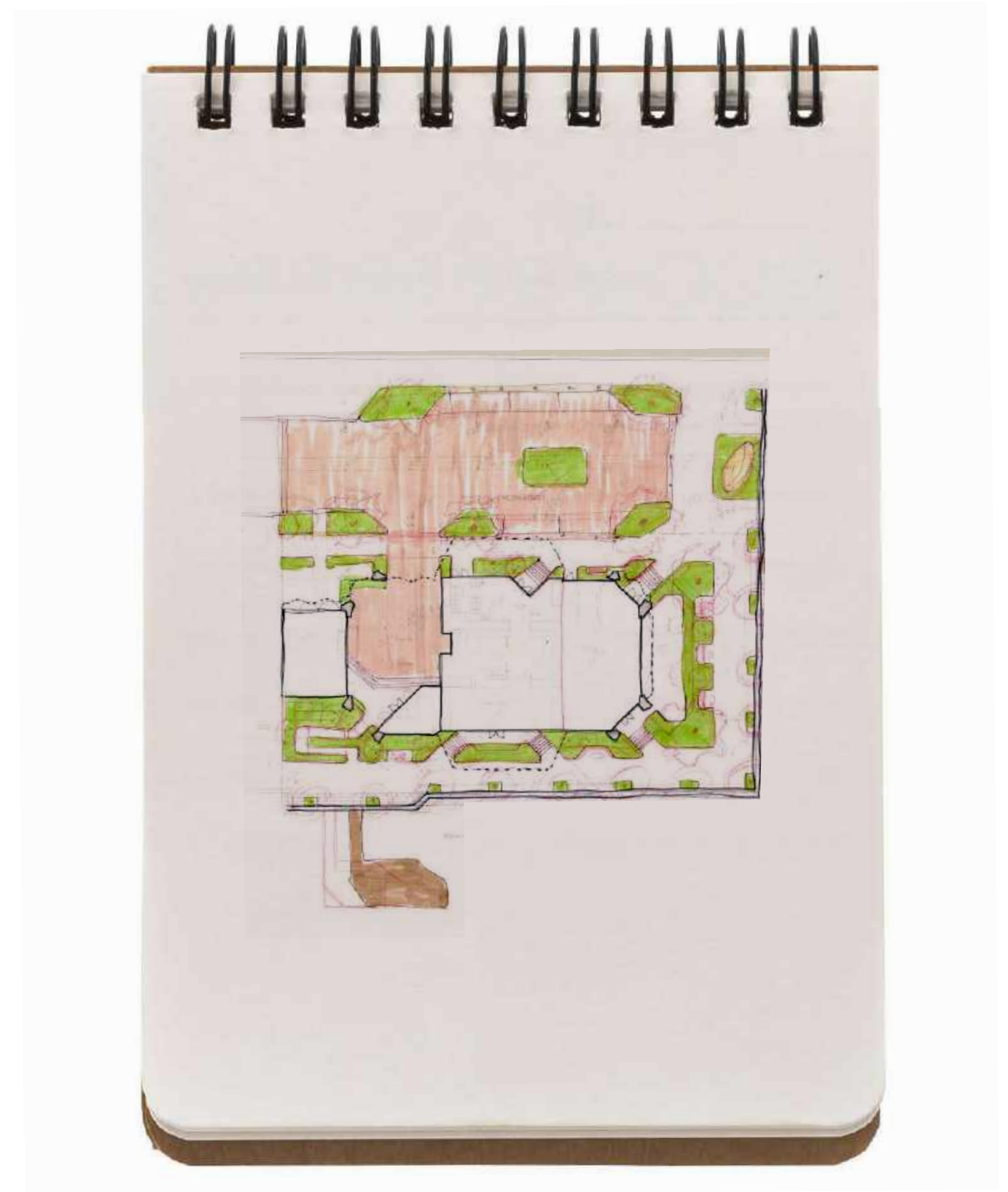

06

A LIFE CURATED

THIS IS A LIFE WRAPPED IN OAK & MARBLE, ENDLESS DAYS ON THE WATER, AND THE TASTE OF THE SUN RISING OVER THE ATLANTIC

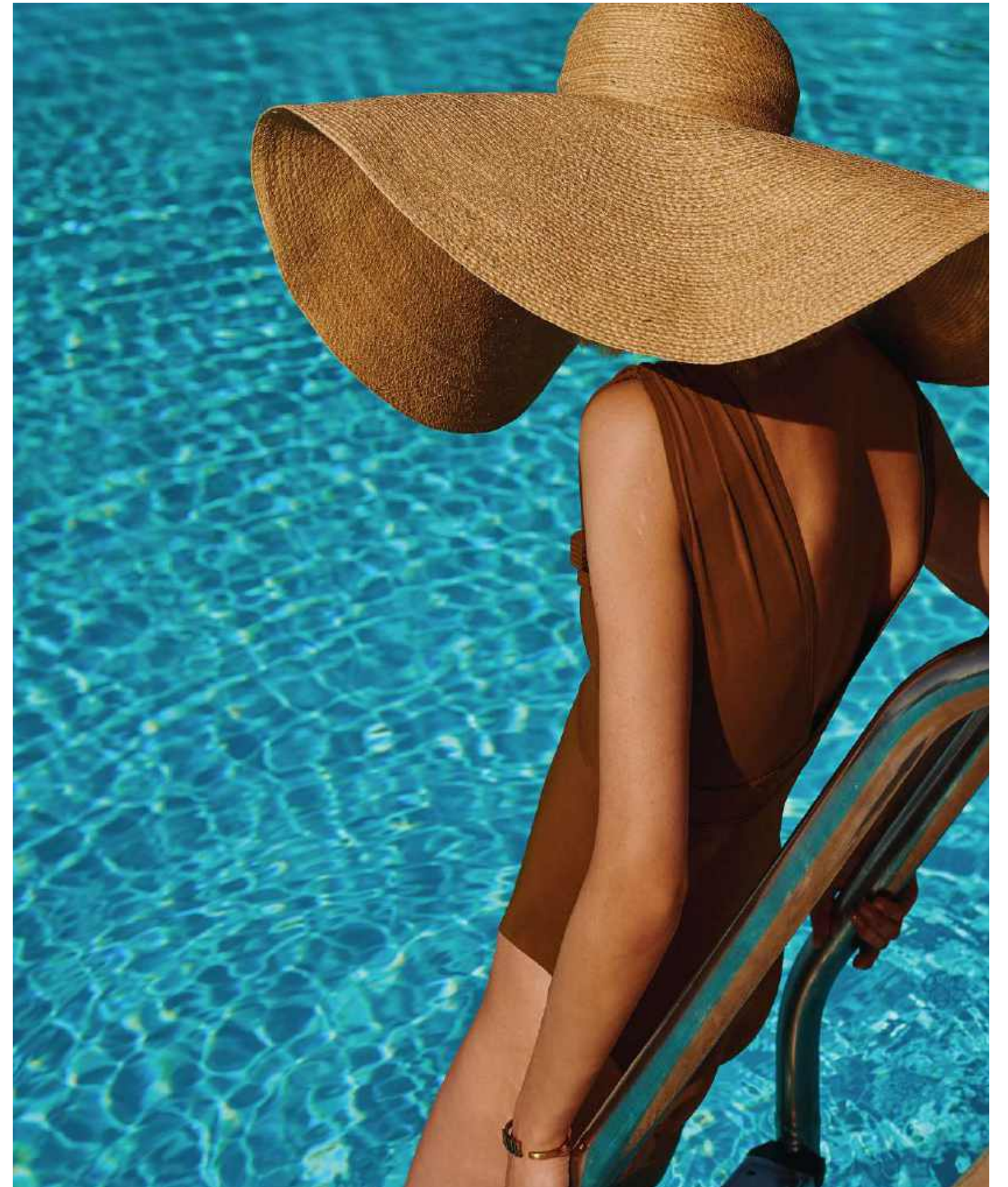

At Villa Miami, the waterfront lifestyle extends beyond the pool deck or the bay to a wider ethos around service and luxury.

REVIVING OLD-WORLD LUXURY

Villa Miami's new vision for waterfront living entails much more than the breathtaking views of the bay. Each day is more enticing than the last, overflowing with possibility and infused with serendipity.

You'll wake up to the smell of fresh coffee and bagels, courtesy of Sadelle's, as you gaze out over the picturesque Venetian Islands and contemplate your day. Perhaps you start the morning with a session in the gym with your trainer, followed by an invigorating stint in the sauna or the Mediterranean spa's tiled plunge pool and a fresh juice. Your boat is ready for you downstairs at the dock, your private cove, begging to be unleashed along the edge of the bay.



At Villa Miami, quality service is an art form, informed by tradition but constantly evolving.



Then it's time to explore the city. Your car is already idling outside. You have advance tickets to that exhibit, which happens to be just minutes away, or you grab a light lunch in between meetings downtown or appointments in the design district. As the sun sets, you head home, flanked by the canopy trees that mark your return. There's a wine tasting in the lounge, a perfect ritual to start the evening. And tonight? Your table is waiting for you at the city's best new restaurant, which just happens to be downstairs. Or maybe you'd rather entertain at home this time, impressing your friends with a little help from chef Mario Carbone, on call for cooking lessons. What next? The helipad beckons. The night can take you anywhere, just as the day does.

How is it all possible? Behind the scenes, orchestrating every day with seamless precision, is our very own majordomo, Villa Miami's in-house curator and Major Domo. Whether you need impossible-to-get tickets or the perfect gift for your in-laws, the curator is at your disposal and up for any challenge. While the concept may be familiar from hotel experiences, the curator is more than a traditional concierge, not unlike a personal assistant, but closer to a chief of staff. Their meticulous attention creates an ecosystem of conveniences that cocoon you and anticipate your every need — creating an invaluable experience for residents, one as integral to the Villa Miami lifestyle as the panoramic views that greet them every morning.



A WATERFRONT RESTAURANT WITH YOUR TABLE WAITING, OR AN IN-HOME CHEF COOKING OFF-MENU

FIVE-STAR DINING EVERY NIGHT OF THE WEEK

Pop downstairs to MFG's latest star restaurant, where the waiters know your favorite dishes by heart, or invite our chefs to your own kitchen for an unforgettable meal at home.

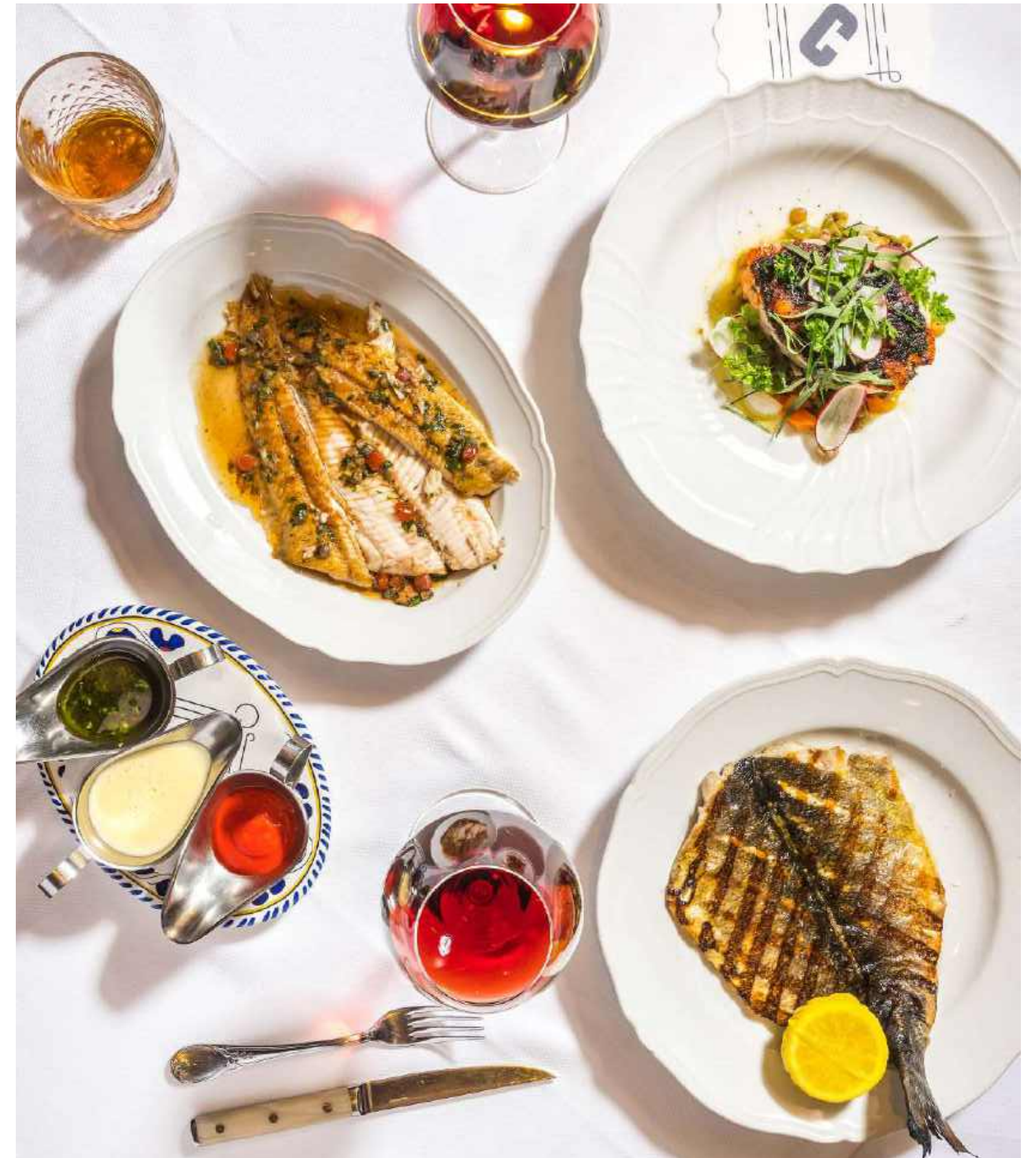

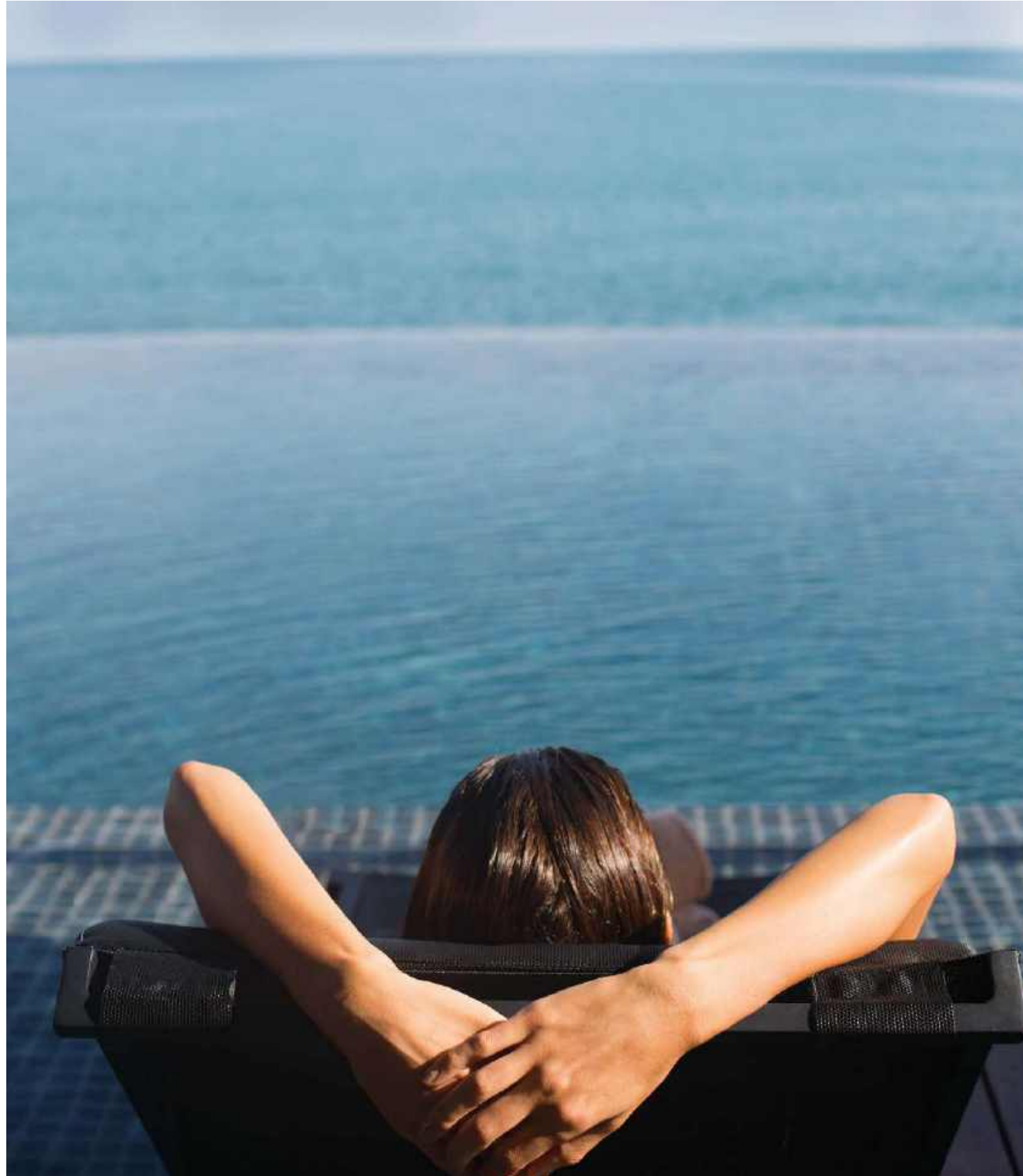

**FIRST-CLASS DAYS
THAT STRETCH INTO
NIGHTS, WHERE
SHEER ABUNDANCE
MEETS SPIRITUAL
INDULGENCE**

**HERE, THE CURATOR
ALWAYS PICKS
THE RIGHT GIFT
FOR THE IN-LAWS
& ANY NEED
ARRIVES PROMPTLY
AT YOUR DOOR**



FREEDOM OF MOVEMENT

Whether you arrive by land, by bay or by air, Villa Miami's unique waterfront location ensures you'll always be met by an epic view.

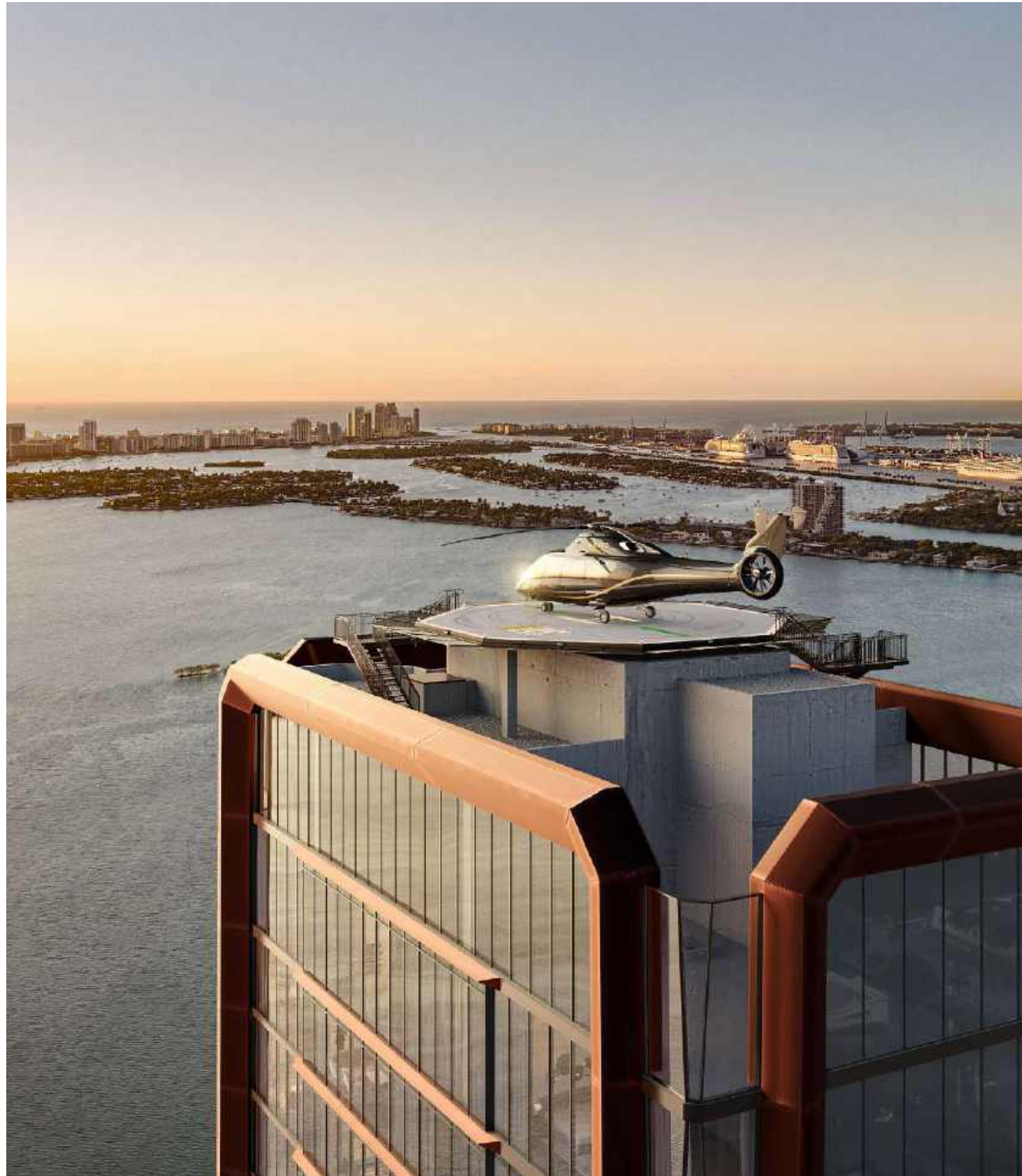

**TIE OFF THE
BOAT AT SUNRISE
AND LIFT OFF
FROM THE HELIPAD
AT SUNSET**



SALES GALLERY

**2742 BISCAYNE BLVD
MIAMI, FLORIDA 33137**

CONTACT

**786.453.4427
INFO@VILLAMIAMI.COM**



710 NE 29TH ST MIAMI, FL 33137



The Condominium is not owned, developed, or sold by Major Food Groups or its affiliates ("MFG"). This condominium is being developed by 710 Edge Property, LLC, a Delaware limited liability company ("Developer"), which has a limited right to use the trademarked names and logos of Terra, One Thousand Group and which uses the Villa marks under a license from MFG, which has not confirmed the accuracy of any of the statements or representations made about the project by the Developer. Any and all statements, disclosures and/or representations shall be deemed made by Developer and not by Terra, One Thousand Group or MFG and you agree to look solely to Developer (and not to Terra, One Thousand Group or MFG and/or its or their affiliates) with respect to any and all matters relating to the marketing and/or development of the Condominium and with respect to the sales of units in the Condominium. These materials are not intended to be an offer to sell, or solicitation to buy a unit in the Condominium. Such an offering shall only be made pursuant to the prospectus (offering circular) for the condominium and no statements should be relied upon unless made in the prospectus or in the applicable purchase agreement. In no event shall this brochure be considered an offer to sell, or solicitation of an offer to buy, condominium units in New York or to residents of New York, or residents of any other jurisdiction were prohibited by law. The project graphics, renderings and text provided herein are copyrighted works owned by the Developer. All rights reserved. Unauthorized reproduction, display or other dissemination of such materials is prohibited. No real estate broker or sales agent (whether engaged by either developer or not) is authorized to make any representations or other statements regarding the project and no agreements with, funds paid to or other arrangements made with any real estate broker are or shall be binding on the Developer. The sketches, renderings, graphic materials, plans, specifications, terms, conditions and statements contained in this brochure are proposed only, and the Developer reserves the right to modify, revise or withdraw any or all of same in its sole discretion and without prior notice. All improvements, designs and construction are subject to first obtaining the appropriate federal, state and local permits and approvals for same. The developer expressly reserves the right to make modifications, revisions, and changes it deems desirable in its sole and absolute discretion. The illustrations and images are conceptual and may vary from concept to actual construction. The images are examples and do not reflect the design or décor of the completed Condominium. The floor plan, unit layout, locations of windows, doors, closets, plumbing fixtures, mechanical equipment, appliances, structural elements, architectural design elements, views, and the uses, configurations, and entries to rooms may change based on final approved plans, permitting, and completed construction. The furniture plan and the uses of space illustrated are suggested uses only and not intended to guaranty or represent any specific use of space. Consult only the Developer's Prospectus for the Condominium to learn terms, conditions, specifications, estimated costs, and to learn what is included with a Unit purchase and how to calculate the Unit size. The balconies depicted are conceptual and the size will vary based on final permitting and completed construction. Restaurants, culinary experiences, and other business establishments and/or any operators of same referenced herein are subject to change at any time, and no representations regarding restaurants, culinary experiences and/or other businesses and/or operators within the Condominium may be relied upon. Restaurants, culinary experiences and/or other business establishments are anticipated to be operated from the commercial components of the Condominium which will be offered for sale to third parties. Determination regarding use of the commercial components will be in the discretion of the purchasers of those spaces and there is no assurance that they will be used for the purposes, and/or with the operators, named herein. The private dock and vessel are subject to obtaining applicable permits and approvals, which have not yet been obtained. There is no guarantee that the project will include a private dock and/or vessel. Use and operation of any helipad is conditioned upon obtaining FAA and other governmental approvals. Approval has not yet been obtained and there is no assurance that the project will include a Helipad. Additionally, since the Helipad, to the extent approved, is anticipated to be operated from a commercial component of the Condominium which will be offered for sale to third parties, there is no assurance that it will be operated as such. All residence features and building amenities are subject to change, including, without limitation, changes in manufacturers, brands, amenities, services and/or the design team. Certain finishes, furnishings and services, may not be included with the purchase of a unit, and if provided, may be upgrades or extras and require additional payments. Consult the Developer's prospectus and the Agreement for a description of those features/items which are to be included in the units. All dimensions and ceiling heights are approximate and may vary with actual construction, and all floor plans and development plans are subject to change. Additionally, Ceiling heights are measured from top of slab to top of slab and exclude areas where any soffits, moldings, drop and/or suspended ceilings and/or light fixtures may be installed. As such, the referenced ceiling height may not represent actual ceiling clearance. The floorplan designs, fixtures, furnishings, finishes, and décor depicted include creations and selections which may not be included with the purchase of a Unit. There may be finishes are available to purchase as an upgrade to your Unit. Consult the Prospectus for the developer of the tower in which you are purchasing for information regarding the Unit designs and to learn what is included with your Unit purchase and what upgrades may be available at additional cost. The Condominium views will vary depending on the Unit purchased. No view, water or otherwise, is guaranteed. The beach club referenced in this brochure is not located onsite at the Condominium. It is to be located off-site and is anticipated to be provided through a separate agreement with a third party and may be for a limited term. THE COMPLETE OFFERING TERMS ARE IN A CPS-12 APPLICATION AVAILABLE FROM THE OFFEROR. FILE NO. CP23-0086 [☞](#)

EXCLUSIVE SALES BY DOUGLAS ELLIMAN DEVELOPMENT MARKETING